

Bermuda 54" (Oasis)
POAS_54AAAARJ1
Yardmore Oval

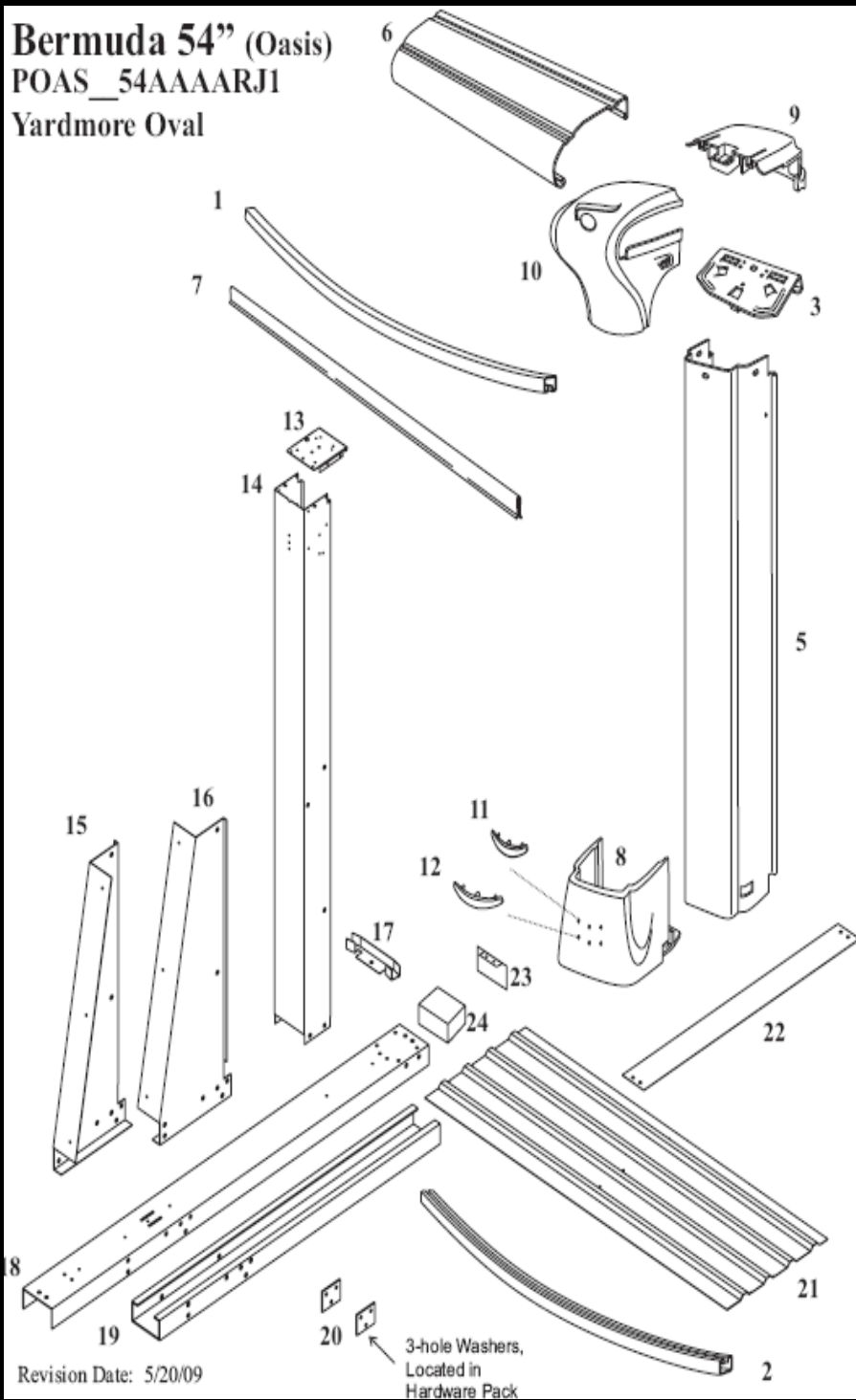

Revision Date: 5/20/09

3-hole Washers,
 Located in
 Hardware Pack

BERMUDA OVAL 18X40' – 54"

NB1264

FRAME CARTON # CROAS18TA-12

Key	Item #	Mfg Part #	Description
6	NBP3035	29803	TOP RAIL

FRAME CARTON # CROASUA51-14

5	NBP3032	29799	UPRIGHT
---	---------	-------	---------

FRAME CARTON # CVOASTA-10

6	NBP3037	29805	TOPRAIL 41 1/4"
21	NBP3164	16549	PRESSURE PLATE

FRAME CARTON # CVOASVA54-12

14	NBP3020	26340	OVAL UPRIGHT
17	NBP3163	16542	CONNECTOR
18	NBP3162	16539	STRAP OVER CHANNEL
22	NBP3167	16726	STRAP SECTION
23	NBP3168	22726	OVAL CHANNEL END CAP
24	NBP3113	29917	OVAL CHANNEL FOAM BLOCK

FRAME CARTON # CVUCGDSD-0404

15	NBP3004	17865	YARDMORE LEFT GUSSET
16	NBP3005	17866	YARDMORE RIGHT GUSSET
19	NBP3161	15933	UNDER CHANNEL

FRAME CARTON # CXOAS1840-AARJ1

1	NBP3016	22719	TOP TRACK 47 1/4"
1	NBP3019	22722	TOP TRACK 36 1/2"
2	NBP3011	22630	BOTTOM RAIL 37 1/2"
2	NBP3008	22627	BOTTOM RAIL 50"
2	NBP3012	22631	BOTTOM RAIL 39"
3	NBP3103	16298	TOP PLATE 6 1/2"
7	NBP3013	22650	BEADED LINER TRACK SLAT
8	NBP3110	27117	8" BOOT
9	NBP3104	16300	8" SMALL INNER TOP CAP
10	NBP3105	16301	8" LARGE OUTER TOP CAP CURVED
10	NBP3106	16302	8" LARGE OUTER TOP CAP STRAIGHT
11	NBP3107	16305	UPRIGHT ACCENT CLIP
12	NBP3108	16356	BOOT ACCENT CLIP

Oasis Slat Wall Pool

POAS_54AAAARJ1

Wall Panel Detail

The Slat Wall system of the Oasis pool features 4 different style aluminum panels that are assembled together to complete the wall of the pool.

See Slat Wall Pool System Instruction Manual for additional detail on assembly.

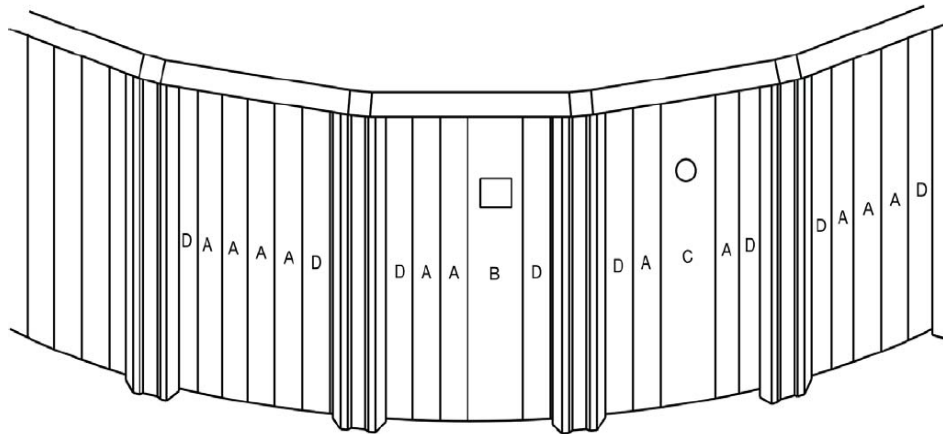
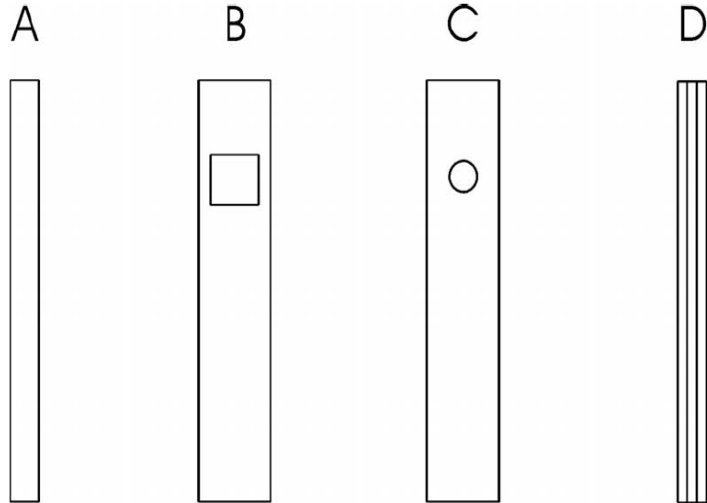

- A is a regular slat
- B is a skimmer slat
- C is a return slat
- D is a beam slat

BERMUDA OVAL 18X40' – 54"

NB1264

FRAME CARTON # CW54R-56

Key	Item #	Mfg Part #	Description
A	NBP3028	26513	REGULAR WALL SLAT 53 5/8"

FRAME CARTON # CW54R-86

A	NBP3028	26513	REGULAR WALL SLAT 53 5/8"
---	---------	-------	---------------------------

FRAME CARTON # CW54RB-4722B

A	NBP3028	26513	REGULAR WALL SLAT 53 5/8"
B	NBP3021	26341	SKIMMER WALL SLAT
C	NBP3022	26342	RETURN WALL SLAT
D	NBP3029	26515	BEAM WALL SLAT

Pool Carton Breakout

POAS-YM184054AAAARJ1

OASIS OVAL YM 1840-54 CC:AAAARJ1

Features: Yardmore Oval
Size: 1840
Depth: 54

Notes: Component materials specified in
"Structure Composition" table

Structure Composition

Aluminum top rails
Aluminum uprights
Aluminum bottom rails
Aluminum-square stabilizers
Resin bottom plates

	Qty	Carton Part#	Carton Content Description
<input type="checkbox"/>	1	CROAS18TA-12	OASIS - TOP RAIL-ALUMINUM
<input type="checkbox"/>	1	CROASUA54-14	OASIS - 54" UPRIGHT CURVED SIDE-ALUMINUM
<input type="checkbox"/>	1	CVOASTA-04	OASIS - OVAL PARTS; TOP RAIL-ALUMINUM
<input type="checkbox"/>	1	CVOASTA-10	OASIS - OVAL PARTS; TOP RAIL-ALUMINUM
<input type="checkbox"/>	1	CVOASVA54-12	OASIS - 54" OVAL PARTS; PLASTIC COPING; STRAP; UPRIGHT STRAIGHT SIDE-ALUMINUM
<input type="checkbox"/>	1	CVSTRAP18-12	UNIVERSAL - OVAL PARTS; STRAP
<input type="checkbox"/>	3	CVUCGDSD-0404	UNIVERSAL - OVAL PARTS; STRAIGHT SIDE PARTS
<input type="checkbox"/>	1	CXOAS1840-AARJ1	OASIS - STABILIZER-ALUMINUM; BOTTOM RAIL ALUMINUM; PLASTIC COPING; TOP COVER; TOP PLATE
<input type="checkbox"/>	1	CW54R-56	UNIVERSAL - RAW EXTRUTIONS
<input type="checkbox"/>	1	CW54R-86	UNIVERSAL - RAW EXTRUTIONS
<input type="checkbox"/>	1	CW54RB-4722B	UNIVERSAL - WALL/52 SLAT TPE INTREPID; SKIMMER GASKET; RAW EXTRUTIONS; WALL COILS & SLATS PAINTED
<input type="checkbox"/>	1	CW54RB-8806	UNIVERSAL - RAW EXTRUTIONS; WALL COILS & SLATS PAINTED

CROAS18TA-12

OASIS 18 FRAME COMPONENTS - CURVED-SIDE

Dwg Ref	QUANTITY	PART #	DESCRIPTION
6	12	29803	TR 8" TAUPE ALUM OAS/NAV 18/33 51 29/32"

*** Packaging Materials Used (These are not pool components!) ***

	1	97-0272B	CARTON-EMPTY (SLS/SIL 15/18/20 TR/UP)B
	1	97-0272T	CARTON-EMPTY (SLS/SIL 15/18/20 TR/UP)T

CROASUA54-14

OASIS 54 FRAME COMPONENTS - CURVED-SIDE

Dwg Ref	QUANTITY	PART #	DESCRIPTION
5	14	29799	UR 6.5" TPE ALUM 53 13/16 OAS/NAV

*** Packaging Materials Used (These are not pool components!) ***

	1	97-0272B	CARTON-EMPTY (SLS/SIL 15/18/20 TR/UP)B
	1	97-0272T	CARTON-EMPTY (SLS/SIL 15/18/20 TR/UP)T

CVOASTA-04

OASIS FRAME COMPONENTS - OVAL STRIAGHT-SIDE

Dwg Ref	QUANTITY	PART #	DESCRIPTION
21	4	16549	PRESSURE PLATE (44")
6	4	29805	TR 8" TAUPE ALUM OAS/NAV STR SD 41 1/4"

*** Packaging Materials Used (These are not pool components!) ***

	1	97-0283B	CARTON-EMPTY MAJ/OYB STR SIDE #8CTN(BTM)
	1	97-0283T	CARTON-EMPTY MAJ/OYB STR SIDE #8CTN(TOP)

CVOASTA-10

OASIS FRAME COMPONENTS - OVAL STRIAGHT-SIDE

Dwg Ref	QUANTITY	PART #	DESCRIPTION
21	8	16549	PRESSURE PLATE (44")
6	10	29805	TR 8" TAUPE ALUM OAS/NAV STR SD 41 1/4"

*** Packaging Materials Used (These are not pool components!) ***

	1	97-0276B	CARTON-EMPTY (STR SIDE/PRESSURE PLATE)B
	1	97-0276T	CARTON-EMPTY (STR SIDE/PRESSURE PLATE)T

CVOASVA54-12

OASIS 54 FRAME COMPONENTS - OVAL STRIAGHT-SIDE

Dwg Ref	QUANTITY	PART #	DESCRIPTION
14	12	26340	WRAP UR OVAL TAUPE ALUM 53 13/16"
18	4	16539	STRAP OVER CHANNEL 2" TALL X 52 3/8"
22	6	16726	STRAP SECTION 52 11/16"(FOR 18')
17	4	16542	CONNECTOR BTM RAIL STR SIDE STEEL
23	4	22726	OVAL CHANNEL END CAP
24	12	29917	OVAL CHANNEL FOAM BLOCK 2 X 4 X 4 1/8

*** Packaging Materials Used (These are not pool components!) ***

	1	97-0057B	CARTON-EMPTY(6" BAY/SW-RND T.R. CMN)B
	1	97-0057T	CARTON-EMPTY(6" BAY/SW-RND T.R. CMN)T

CVSTRAP18-12

FRAME COMPONENTS - OVAL STRIAGHT-SIDE

Dwg Ref	QUANTITY	PART #	DESCRIPTION
18	8	16539	STRAP OVER CHANNEL 2" TALL X 52 3/8"
22	12	16726	STRAP SECTION 52 11/16"(FOR 18')
17	8	16542	CONNECTOR BTM RAIL STR SIDE STEEL
23	8	22726	OVAL CHANNEL END CAP

*** Packaging Materials Used (These are not pool components!) ***

	1	97-0260T	CARTON-EMPTY UPRIGHT(SOUTHWIND)T
	1	97-0260B	CARTON-EMPTY UPRIGHT(SOUTHWIND)B

CVUCGDSD-0404

FRAME COMPONENTS - OVAL STRIAGHT-SIDE

Dwg Ref	QUANTITY	PART #	DESCRIPTION
19	4	15933	UNDER CHANNEL YARDMORE 45 9/16"
15	4	17865	YARDMORE GUSSET LEFT DESERT SAND(STEEL)
16	4	17866	YARDMORE GUSSET RIGHT DESERTSAND(STEEL)
	1	16720	HDW SS BASE PACK YM(4 UPRIGHTS)

*** Packaging Materials Used (These are not pool components!) ***

	1	97-0278B	CARTON-EMPTY (YARDMORE GUSSET)B
	1	97-0278T	CARTON-EMPTY (YARDMORE GUSSET)T

CW54R-56

FRAME COMPONENTS - WALL SLATS

Dwg Ref	QUANTITY	PART #	DESCRIPTION
A	56	26513	REGULAR SLAT OASIS TAUPE 54" (53 5/8)

*** Packaging Materials Used (These are not pool components!) ***

	1	97-0210T	CK 52" UPRIGHT(TOP)
	1	97-0210B	CK 52" UPRIGHT(BOTTOM)

CW54R-86

FRAME COMPONENTS - WALL SLATS

Dwg Ref	QUANTITY	PART #	DESCRIPTION
A	88	26513	REGULAR SLAT OASIS TAUPE 54" (53 5/8)

*** Packaging Materials Used (These are not pool components!) ***

	1	97-0272T	CARTON-EMPTY (SLS/SIL 15/18/20 TR/UP)T
	1	97-0272B	CARTON-EMPTY (SLS/SIL 15/18/20 TR/UP)B

CW54RB-4722B

FRAME COMPONENTS - WALL SLATS

Dwg Ref	QUANTITY	PART #	DESCRIPTION
B	1	26341	SKIMMER SLAT TAUPE 54" (53 5/8" OAS-PRO)
C	1	26342	RETURN SLAT TAUPE 54" (53 5/8" OAS-PRO)
D	22	26515	BEAM SLAT OASIS TAUPE 54" (53 5/8")
	1	89123	WALL/54 SLAT INTREPID 10 PACK
A	47	26513	REGULAR SLAT OASIS TAUPE 54" (53 5/8)

*** Packaging Materials Used (These are not pool components!) ***

	1	97-0057T	CARTON-EMPTY(6" BAY/SW-RND T.R. CMN)T
	1	97-0057B	CARTON-EMPTY(6" BAY/SW-RND T.R. CMN)B

CW54RB-8806

FRAME COMPONENTS - WALL SLATS

Dwg Ref	QUANTITY	PART #	DESCRIPTION
D	6	26515	BEAM SLAT OASIS TAUPE 54" (53 5/8")
A	88	26513	REGULAR SLAT OASIS TAUPE 54" (53 5/8)

*** Packaging Materials Used (These are not pool components!) ***

	1	97-0272T	CARTON-EMPTY (SLS/SIL 15/18/20 TR/UP)T
	1	97-0272B	CARTON-EMPTY (SLS/SIL 15/18/20 TR/UP)B

CXOAS1840-AARJ1

*OASIS 1840 POOL COMPONENTS - MIXED OVAL
CURVED/STRAIGHT-SIDE*

Dwg Ref	QUANTITY	PART #	DESCRIPTION
9	26	16300	TC 8" MOSAIC SML1/2 INNER
10	14	16301	TC 8" MOSAIC LG 1/2 OUTER CVD (ANT/LYR)
10	12	16302	TC 8" MOSAIC LG 1/2 OUTER STR (ANT/LYR)
12	26	16356	ACCENT CLIP PUMICE RESIN LARGE BOOT(LYR)
11	78	16305	ACCENT CLIP PUMICE RESIN 3-EA UR(LYR)
	1	95-0007	ENVELOPES SAFETY COMPLETE
	1	95-0223	SHARKLINE WARRANTY DIAMOND SERIES BLUE
	1	95-0444	INSTR. WRAP AROUND&YARDMORE BLANK OVAL
	1	95-0735	INSTR INSTALL SLAT WALL POOL YM OVAL
	1	16610	HDW SS ADD ON ESC/SLS/SIL/ELA/EQU 1840
	1	16678	HDW SS ESC/SLS/SIL/ELA/EQU 1530/1833
2	12	22627	BTM RAIL ALUM SLAT WALL 9'0"R 50"
1	12	22719	TOP TRACK ALUM SLAT WALL 9'0"R 47 1/4"
2	20	22630	BTM RAIL ALUM SLAT WALL 9'0"R 37 1/2"
2	4	22631	BTM RAIL ALUM SLAT WALL 9'0"R 39"
1	4	22722	TOP TRACK AL SLAT WALL 9'0"R CRNR36 1/2"
3	14	16298	TOP PLATE 6.5" LYR
8	14	27117	TC 8" MOSAIC BOOT CVD ONLY (ANT/LYR)LX
13	12	10136	TOP PLATE 4" OVAL
7	25	22650	BEADED LINER TRACK SLAT WALL 49" NOTCHED

*** Packaging Materials Used (These are not pool components!) ***

	1	97-0057B	CARTON-EMPTY(6" BAY/SW-RND T.R. CMN)B
	1	97-0057T	CARTON-EMPTY(6" BAY/SW-RND T.R. CMN)T