



# UNIVERSAL INSTRUCTIONS BRACELESS OVAL POOLS

PLEASE READ THESE INSTRUCTIONS CAREFULLY AND THOROUGHLY BEFORE STARTING GROUND PREPARATION AND POOL ASSEMBLY. DOING SO WILL PREVENT PROBLEMS.

	Page.
Oval Pool: General information -----	1
1) Selection of pool site -----	1
2) Ground preparation -----	2
3) Assembling side structural component -----	3
4) Drawing pool shape -----	5
5) Connecting tension straps -----	7
6) Positioning assembled oval parts -----	7
7) Assembling bottom rail -----	8
8) Installing wall -----	8
9) Build an earth mound(Cove) -----	9
10) Through the wall skimmer -----	9
11) Liner installation -----	9
Please refer to "Assemble TopSeat , Vertical and Cover" of an attached sheet.	
12) Filling the pool -----	9
13) Helpful information -----	10
14) SAFETY RULES -----	10
BRACELESS OVAL Parts List -----	11

**GENERAL INFORMATION**

Before attempting to set up the pool, read the entire instructions. There are certain areas in the instructions that are extremely important to follow exactly as written and/or pictured. Any deviation from these instructions voids warranty of the pool and could cause bodily harm or damage to your property.

Open the cartons and remove all parts except steel wall and liner. Before pool assembly, you must identify, count and check all parts for assembly by parts list. Familiarize yourself with all of the parts. Refer to the parts list.

**CAUTION:** Do not start the installation of your pool unless you have an entire day to finish the work.  
Do not try to set up your pool on a windy day.  
The wall will be difficult or even impossible to handle.

An average pool needs 2 or 3 people for installation.  
The following tools and materials are needed.

- |                   |                |                |
|-------------------|----------------|----------------|
| Screwdriver       | Earth Roller   | Shovel         |
| Tamping Tool      | String         | Marking        |
| Pegs and Stakes   | Hammer & Nails | Pencil         |
| Carpenter's Level | Sand           | Masking Tape   |
| Measuring Tape    | 2"x4" Board    | Rake           |
| Patio Block       |                | Chalk or Flour |
|                   |                | Plastic Tape   |

**FAILURE TO OBSERVE ANY OF THE ABOVE INSTRUCTIONS WILL VOID WARRANTY.**

**SIFTED EARTH OR SAND NEEDED PER EACH SIZE POOL AS FOLLOWS:**

16' x 12'	26 cubic feet	0.79cubicM
20' x 12'	34 cubic feet	0.96cubicM
24' x 12'	42 cubic feet	1.19cubicM
25' x 15'	54 cubic feet	1.53cubicM
30' x 15'	66 cubic feet	1.87cubicM
33' x 18'	87 cubic feet	2.46cubicM
41' x 21'	127 cubic feet	3.59cubicM

**1) SELECTION OF POOL SITE**

Before starting the installation, the following points are important;

- The site must be large enough to accommodate the pool with plenty of area around it for pool accessories, chairs, tables etc.
- Determine where your filtration and skimmer will be located. It must be connected to a grounded 110 volt electrical outlet, with a G.F.I. (Ground Fault Interrupter)
- The pool must be in reach of your water supply. Although the water should not be drained, but kept clean through filtration and chemicals, there should be drainage facilities near in case of need.
- Perimeter area of ground must be absolutely level and firm. All grass and sod under entire pool area must be dug out to avoid unpleasant odors from decomposition under the pool due to lack of air. Remove sharp objects, stones, twigs, pebbles, roots, etc. They may damage the liner. If the ground has been treated with chemicals or weed killer allow two weeks before setting up the pool. Do not set up the pool on concrete, asphalt, tar paper, peatmoss, sand, gravel, or where nut grass has been planted. Poorly prepared ground could allow certain weeds or grass to grow through the liner. Liner is not warranted against this. If ground is uneven in perimeter area, dig out the high spots. Do not build up the low side by padding it with earth. The weight and movement of the water will pack down the fill causing the pool to sink. Inside perimeter of pool (the area inside of the frame and wall) can be leveled with 1" or 2" of sand raked and rolled smooth.

POOL SIZE	Wall Length			Top Sheet Q'ty
	mm	ft	in.	
1612	13,855	45	5 4/8	12
2012	16,364	53	8 2/8	14
2412	18,873	61	11	16
2515	20,625	67	8	14
3015	23,756	77	11 2/8	16
3318	26,586	87	2 6/8	18
4121	32,549	106	9 4/8	22

**TOOLS & MATERIALS**

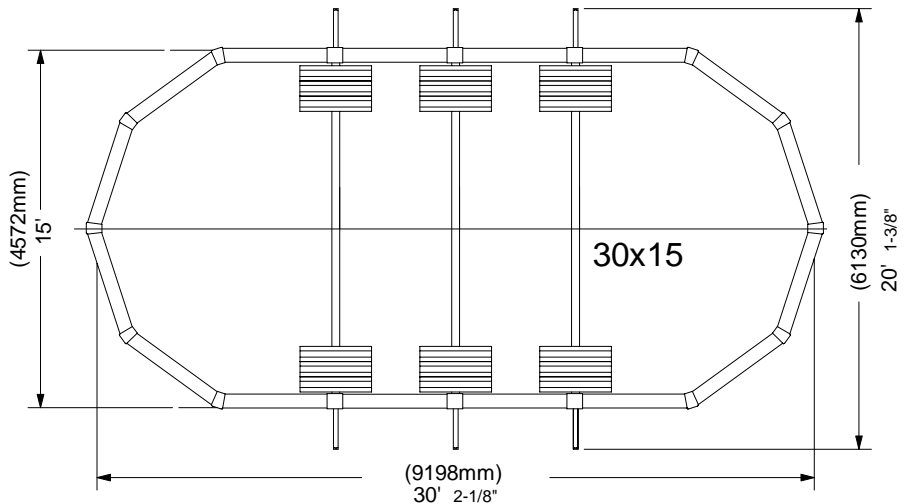
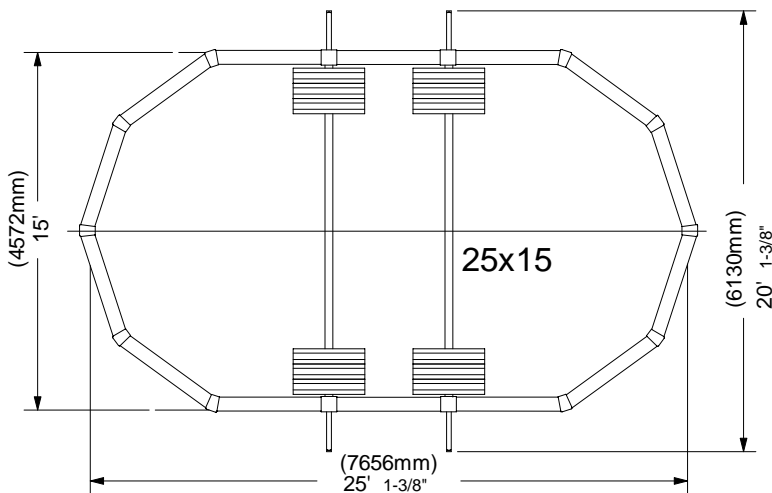
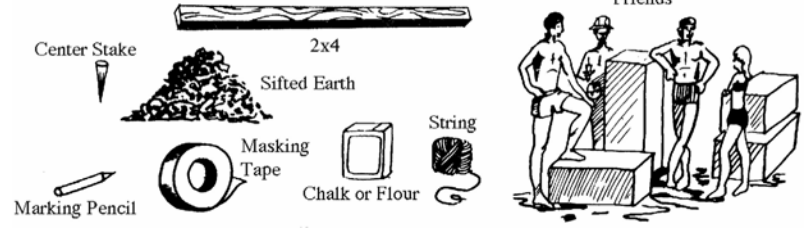
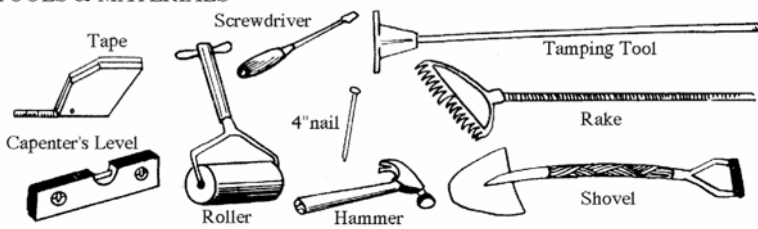

## 2) GROUND PREPARATION

The preparation of the ground is the most important step in the installation of the pool.

a) Mark off your pool area by driving stakes. Have a helper hold a tape measure or a string and mark off the pool perimeter using flour or chalk. Remove sod inside the pool area to a distance of 1 feet beyond dimensions shown in the plot layout around entire perimeter of pool.

b) Remove all grass from within the entire pool area. It is not enough to just cut the grass. The sod must be removed.

c) Two or three inches of sand is the best for your liner. Using sand eliminates the necessity to level inside of frame area except where exceptionally high or low areas exist. These areas should either be dug or filled in. This does not mean the perimeter or frame area. That area must be firm and level by digging only.

d) Do not fill low spots in the area where pool wall will rest. as setting may cause your pool to become out of level. Making sure pool bottom is flat. This is a must.

e) If your site is not on firm soil, use 2" patio blocks for the base of the wall Care should be taken to center a patio block under each bottom plate. The top of the patio blocks should be flush with the prepared ground surface.

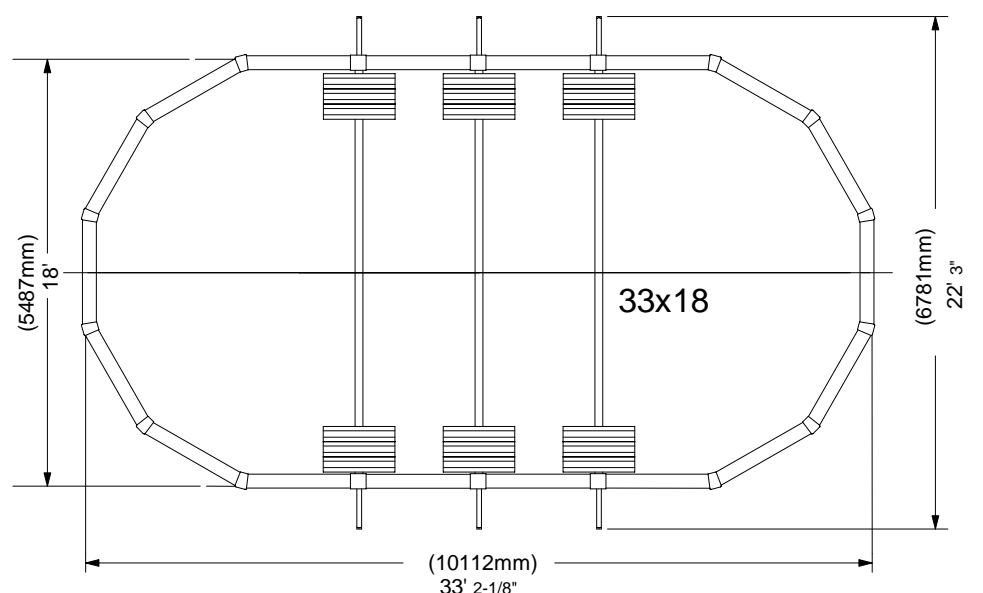
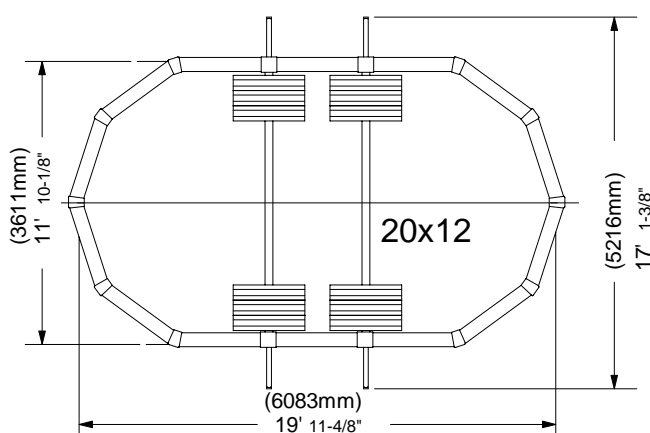
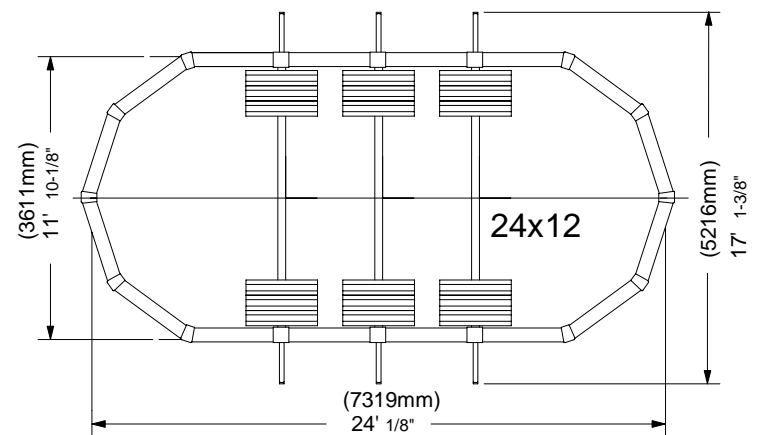
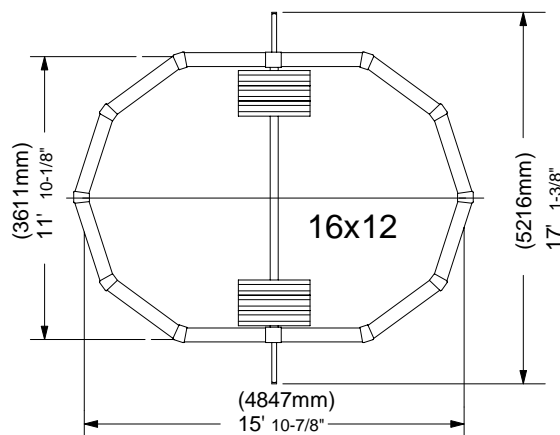
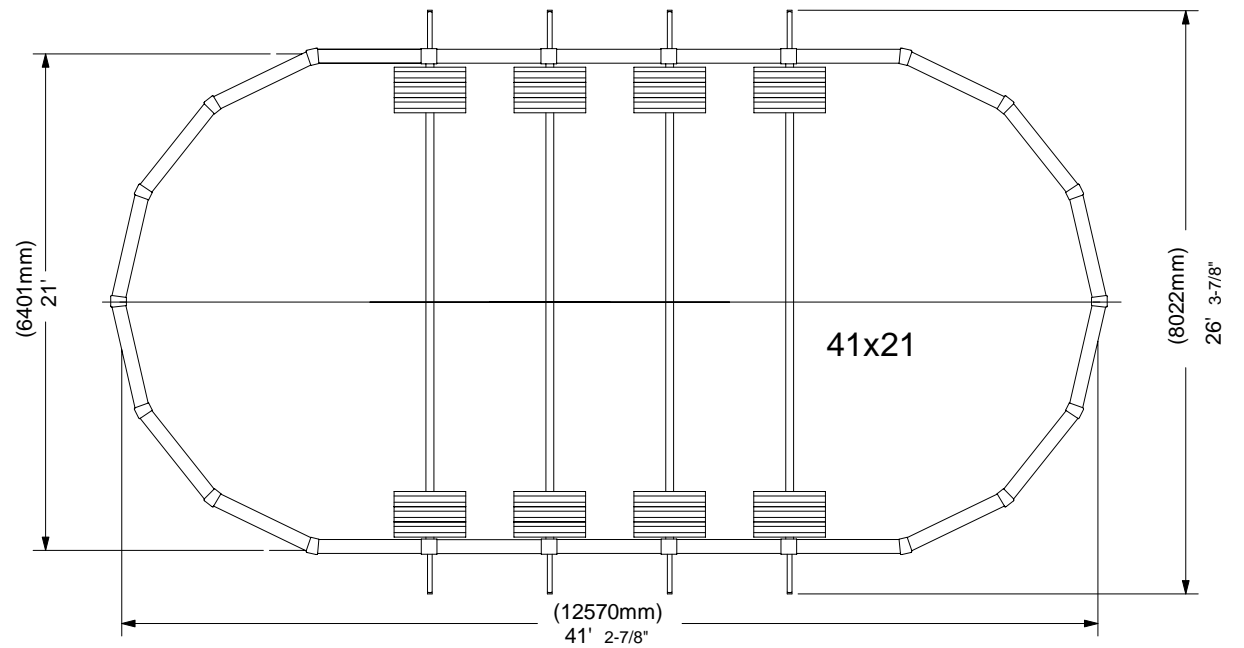

### 3) ASSEMBLING BRACELESS OVAL STRUCTURAL COMPONENT.

Use #0109PACK Braceless Oval frame bolt package.  
Use #0105(#0106)PACK Strap bolt package.

NOTE; Side vertical skin was attached to side vertical at the factory, open end is inside pool.

STEP1.  
Insert Side Vertical into Horizontal Support.  
Insert M14 x 30 Hex Head Bolt from inside of side vertical, put M14 Nut from outside do the same six Bolt on right and left side of side vertical.

STEP2.  
Insert M10x100 Hex Head Bolt and put three M10 Nuts for each bolt. Do the same for three Bolts. as shown picture.

STEP3.  
Make sure all Parts attached correctly.  
Tighten up all bolt.  
Pull Side Vertical toward outside of Pool.

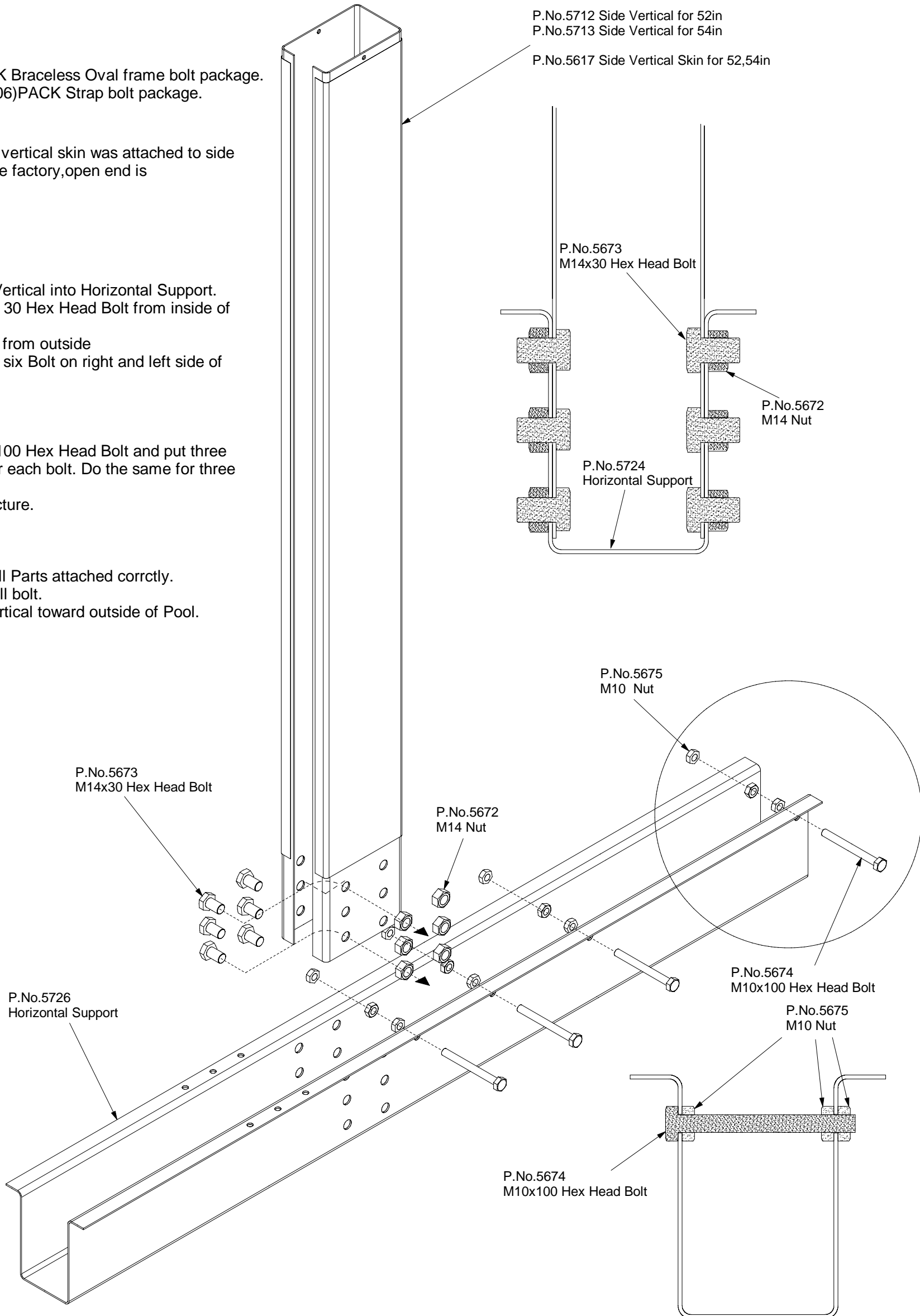

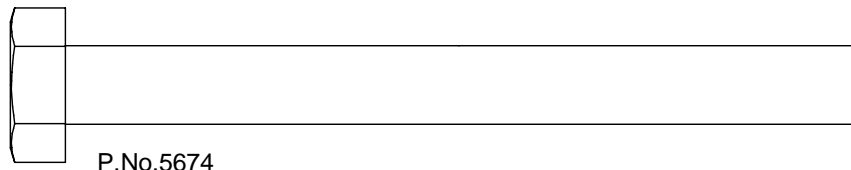

P.No.5674  
M10x100 Hex Head Bolt

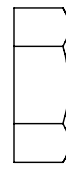

P.No.5675  
M10 Nut

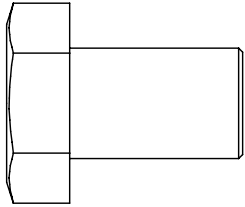

P.No.5673  
M14x30 Hex Head Bolt

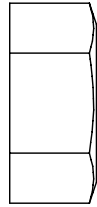

P.No.5672  
M14 Nut

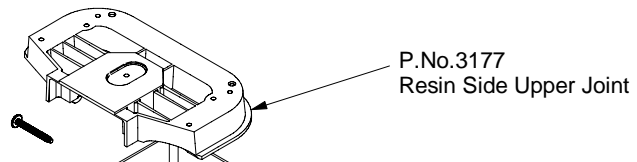

P.No.3177  
Resin Side Upper Joint

**STEP4.**  
Refer page-7 "5)Connecting tension staraps."  
to determine kind of staraps.  
Attach End strap to Horizontal support. Put M8x20  
hex head bolt from top and put  
M8 Nut from bottom. Put all bolt and tighten up.

**STEP5.**  
Attach Side Lower Rail Joint to Horizontal support  
using two sets of #12x3/4 Sheet Metal Screw.

**STEP6.**  
Attach Side Upper Joint to top of side vertical  
using two 5mmx40 Sheet Metal Screw.

P.No.0345  
5mmx40 Sheet Metal Screw

P.No.0345  
5mmx40 Sheet Metal Screw

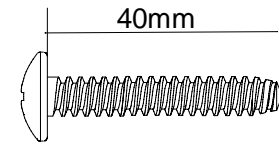

P.No.0341  
#12x3/4 Sheet Metal Screw

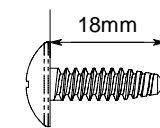

P.No.0341  
#12x3/4 Sheet Metal Screw

P.No.3233  
5/8" Side Lower Rail Joint - For 1" & 6 Frame  
P.No.3222  
1" Side Lower Rail Joint - For All other Frame

P.No.0923  
M8x20 Hex Head Bolt

P.No.7528  
End strap

P.No.0623  
M8 Nut

#### 4) DRAWING POOL SHAPE

Please Draw a line with seeing the picture of each pool size.

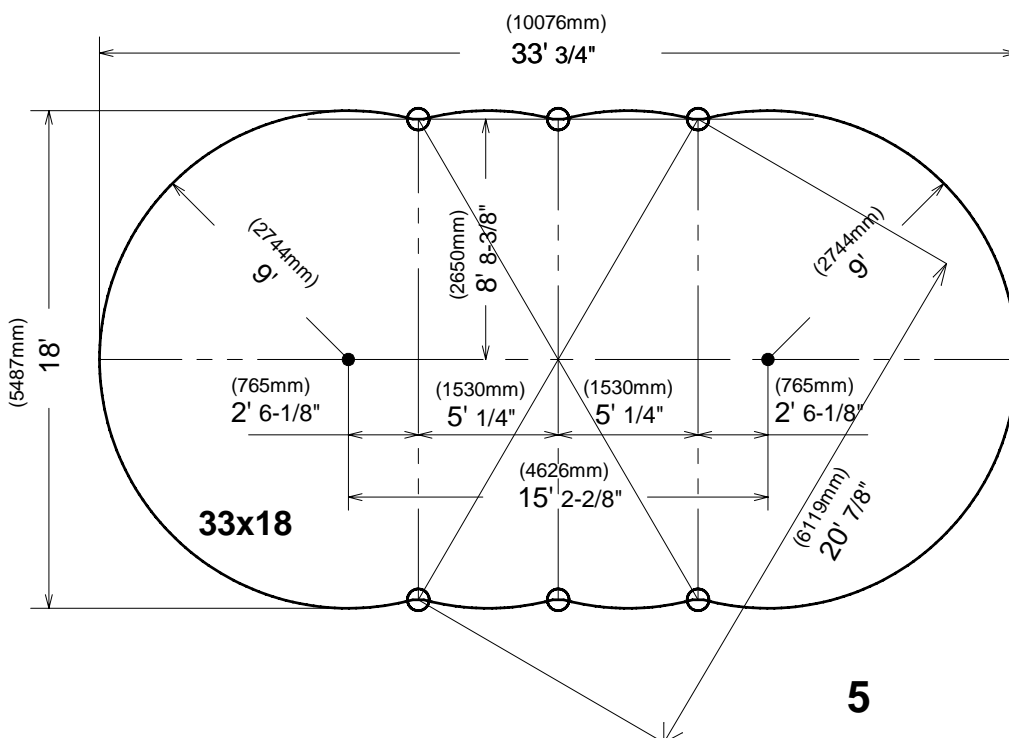
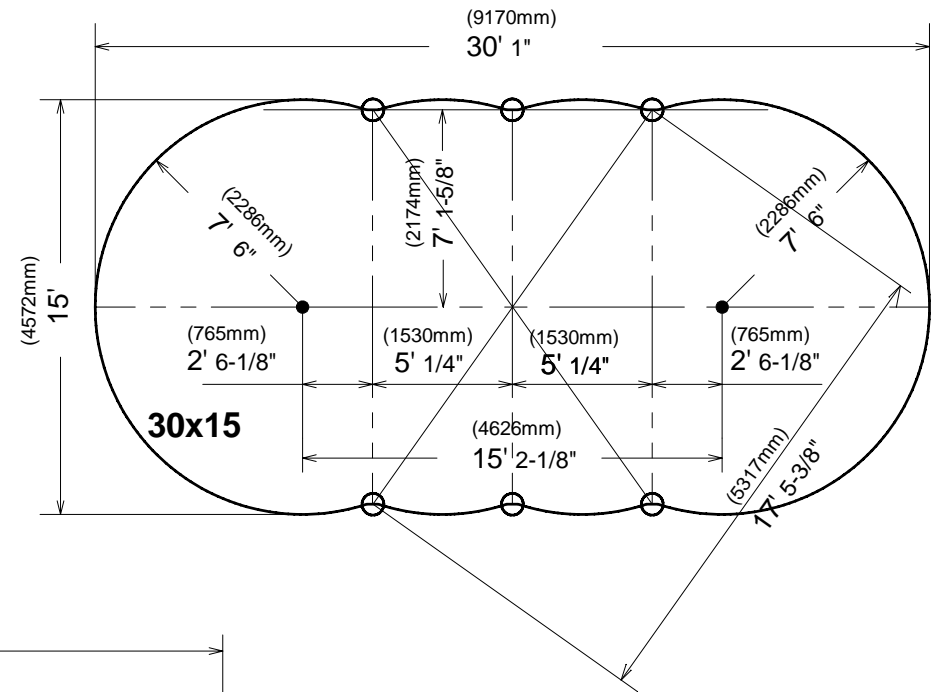
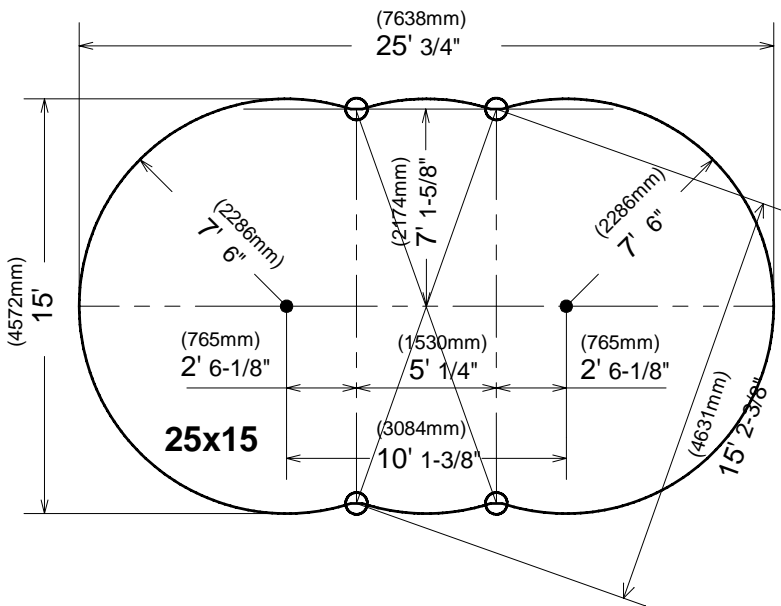
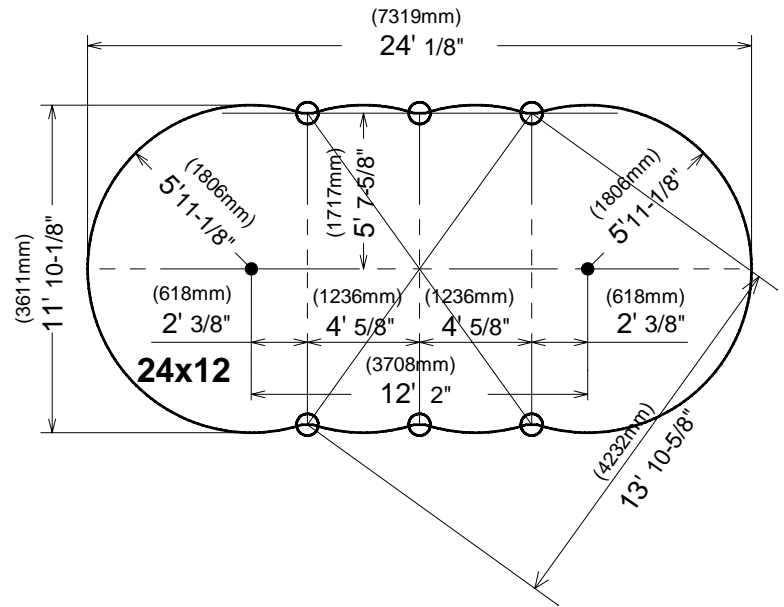
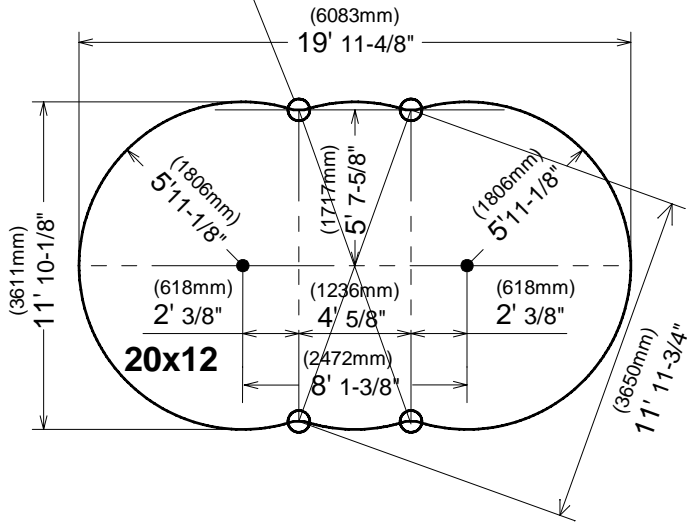
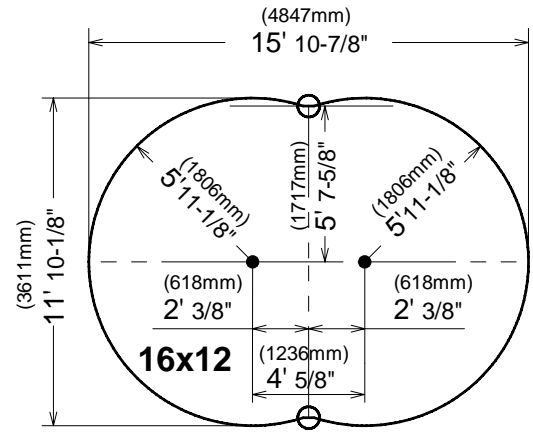
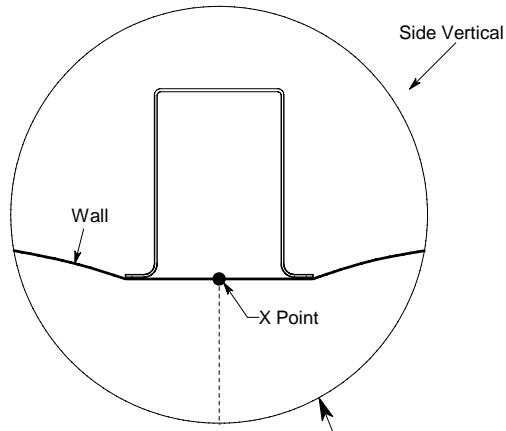

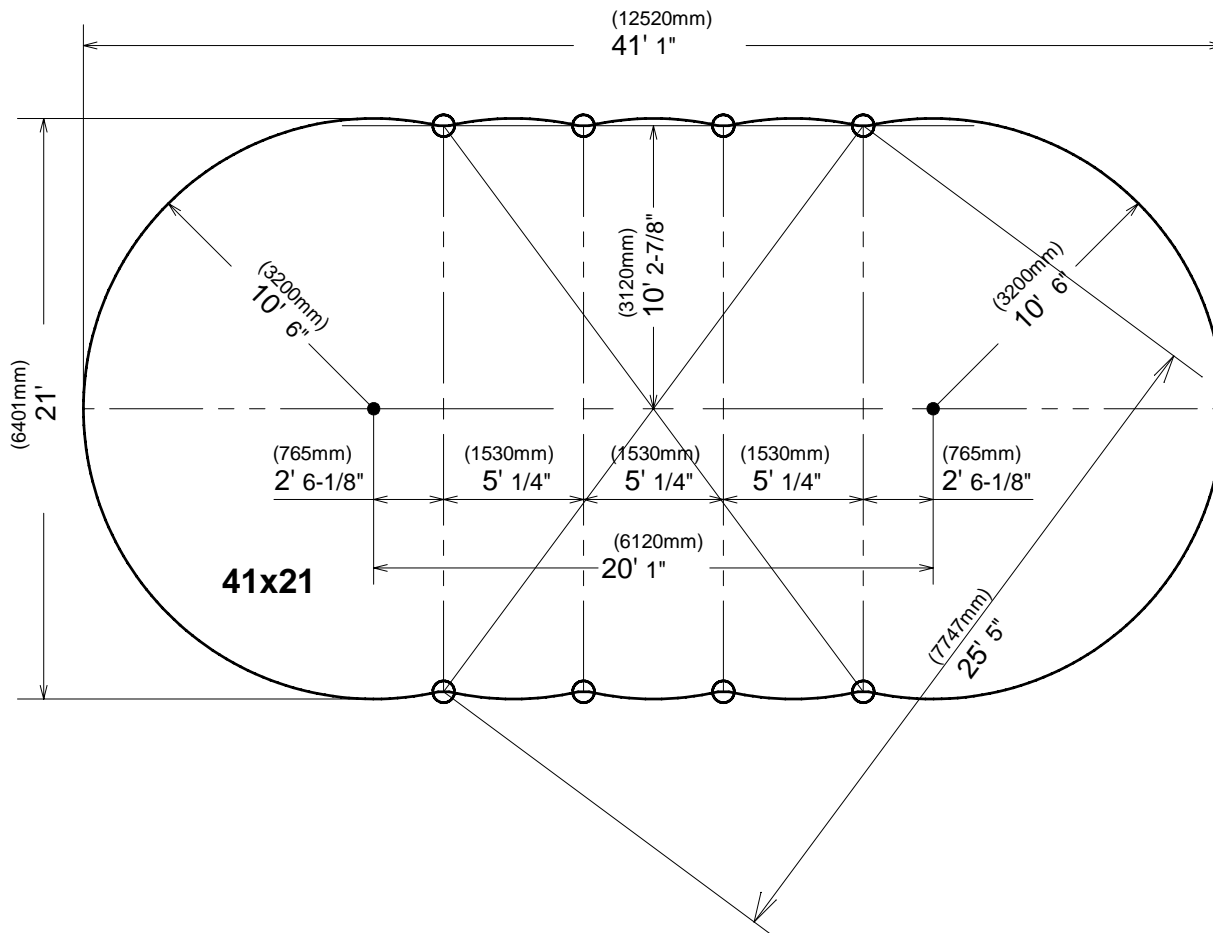

### 5) CONNECTING TENSION STRAPS

Use #0106.PACK Strap Bolt Package  
 Use #0105.PACK Strap Bolt Package

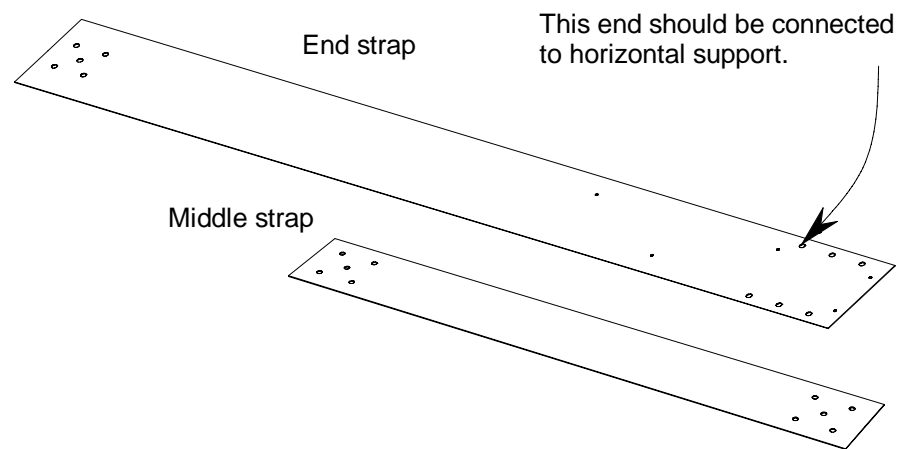
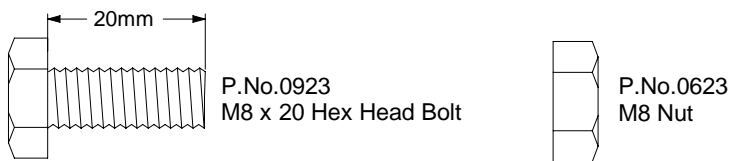

Connect Middle strap(s) to already assembled End straps.  
 Using five sets of M8x20 hex head bolt and M8 nut.

End strap ; 7528 This should be used for the end.  
 Middle strap ; 7254, 7244, 7264 or 7285. Those should be used for the middle.

Length of Tension Straps.

Parts No.	Type	Length(in)	Length(mm)
7528	End	55-1/8"	1400
7254	Middle	32-7/8"	835
7244	Middle	36-5/8"	929
7264	Middle	55-3/8"	1405
7285	Middle	50-5/8"	1286

Combination of Strap Set

	Quantity per set.	Number of sets per pool.
12' Width Oval Pools	7528 - 2pieces 7254 - 1pieces	16x12 - 1straps. 20x12 - 2straps. 24x12 - 3straps.
15' Width Oval Pools	7528 - 2pieces 7244 - 2pieces	25x15 - 2straps. 30x15 - 3straps.
18' Width Oval Pools	7528 - 2pieces 7264 - 2pieces	33x18 - 3straps.
21' Width Oval Pools	7528 - 2pieces 7285 - 3pieces	41x21 - 4straps.

Note:  
 All Bolts to be inserted from the top side, Nuts to be inserted from underneath Tension straps.

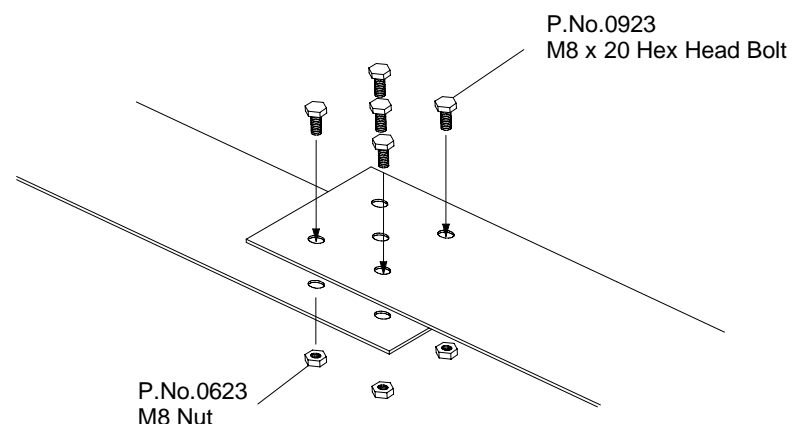

# IMPORTANT !

Digging holes for assembled braceless oval structural components. Use Building block to hold assembled braceless oval structural component. Stamp ground under building block well to bellow than needed level. Put some sand to the ground and pour some water to make sand tight. Then put building block on top of sand. Adjust building block accordingly.

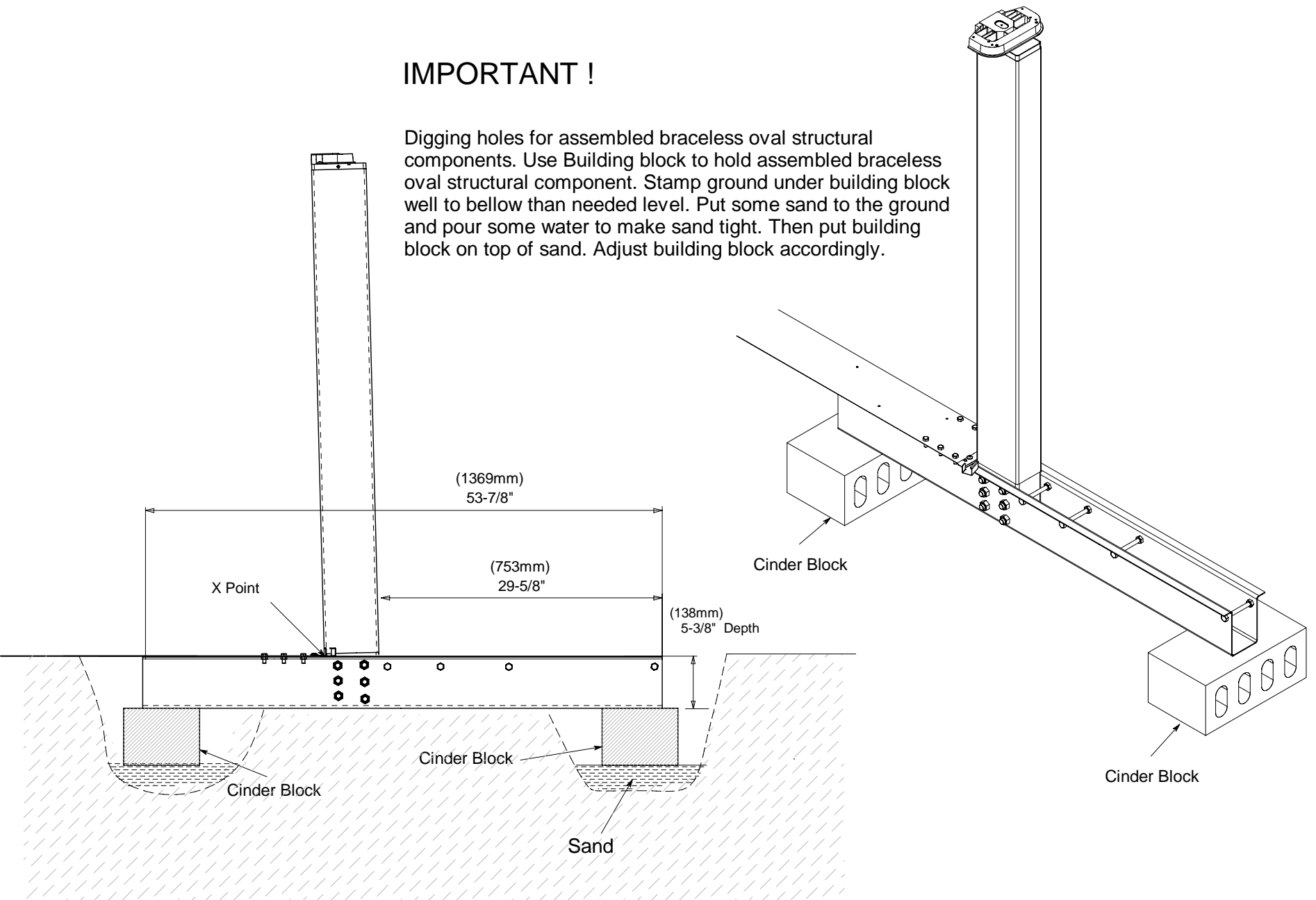

## 6) POSITIONING ASSEMBLED OVAL PARTS.

Set all oval parts on the right position, Check(A) length(distance between horizontal support), Put Top seat on top of side upper joint temporarily as shown figure. Then check a-b,c-d is straight and level,If not, adjust accordingly.

Do not use wood to adjust height.

*Top seat temporarily placed should be removed before proceeding to next step.*

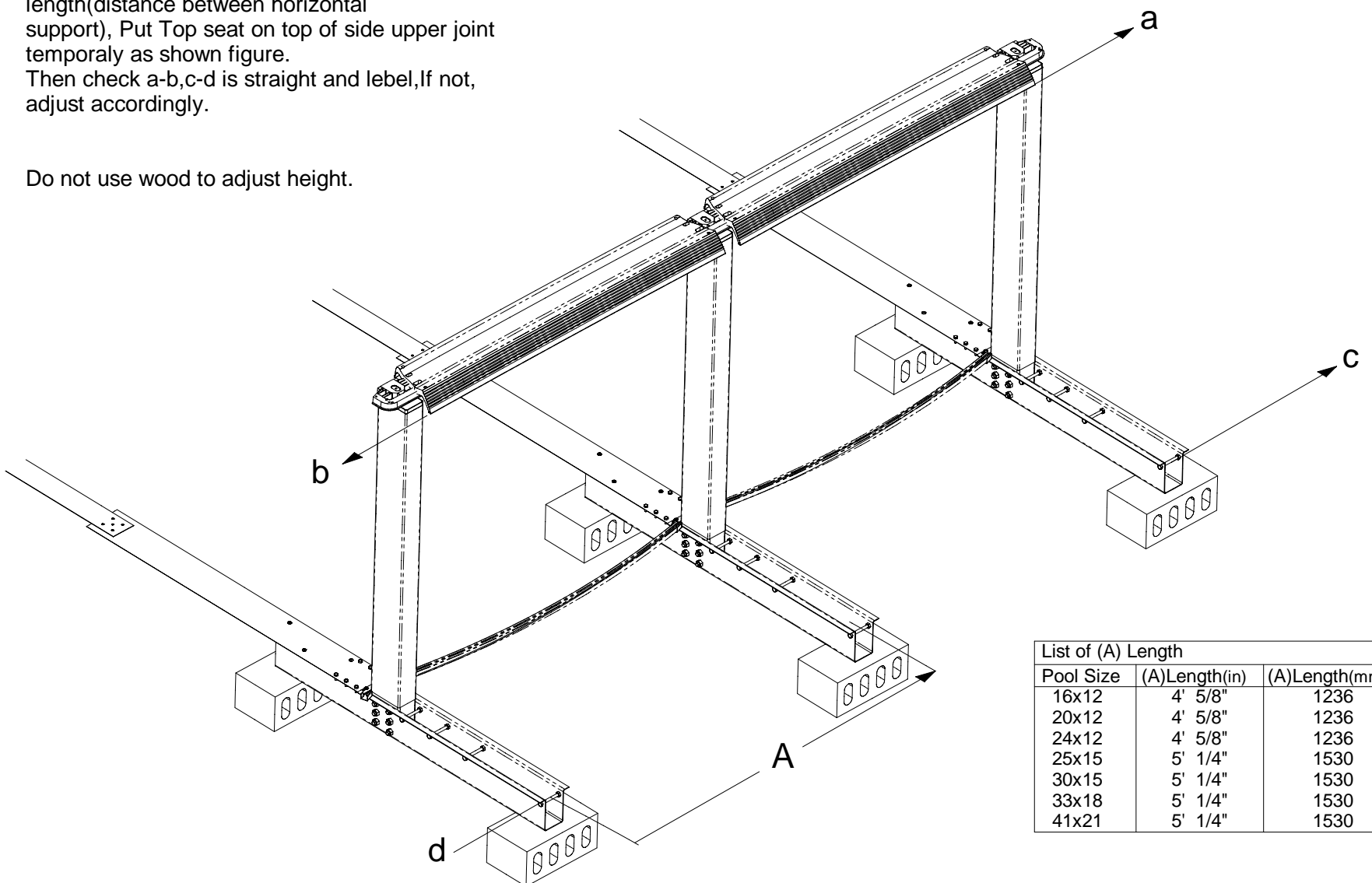

List of (A) Length		
Pool Size	(A)Length(in)	(A)Length(mm)
16x12	4' 5/8"	1236
20x12	4' 5/8"	1236
24x12	4' 5/8"	1236
25x15	5' 1/4"	1530
30x15	5' 1/4"	1530
33x18	5' 1/4"	1530
41x21	5' 1/4"	1530



Put Pressure plate by Using #12x3/4 Sheet Metal Screw after Positioning Assembled oval parts.

P.No.6254  
Pressure Plate

P.No.0341  
#12x3/4 Sheet Metal Screw

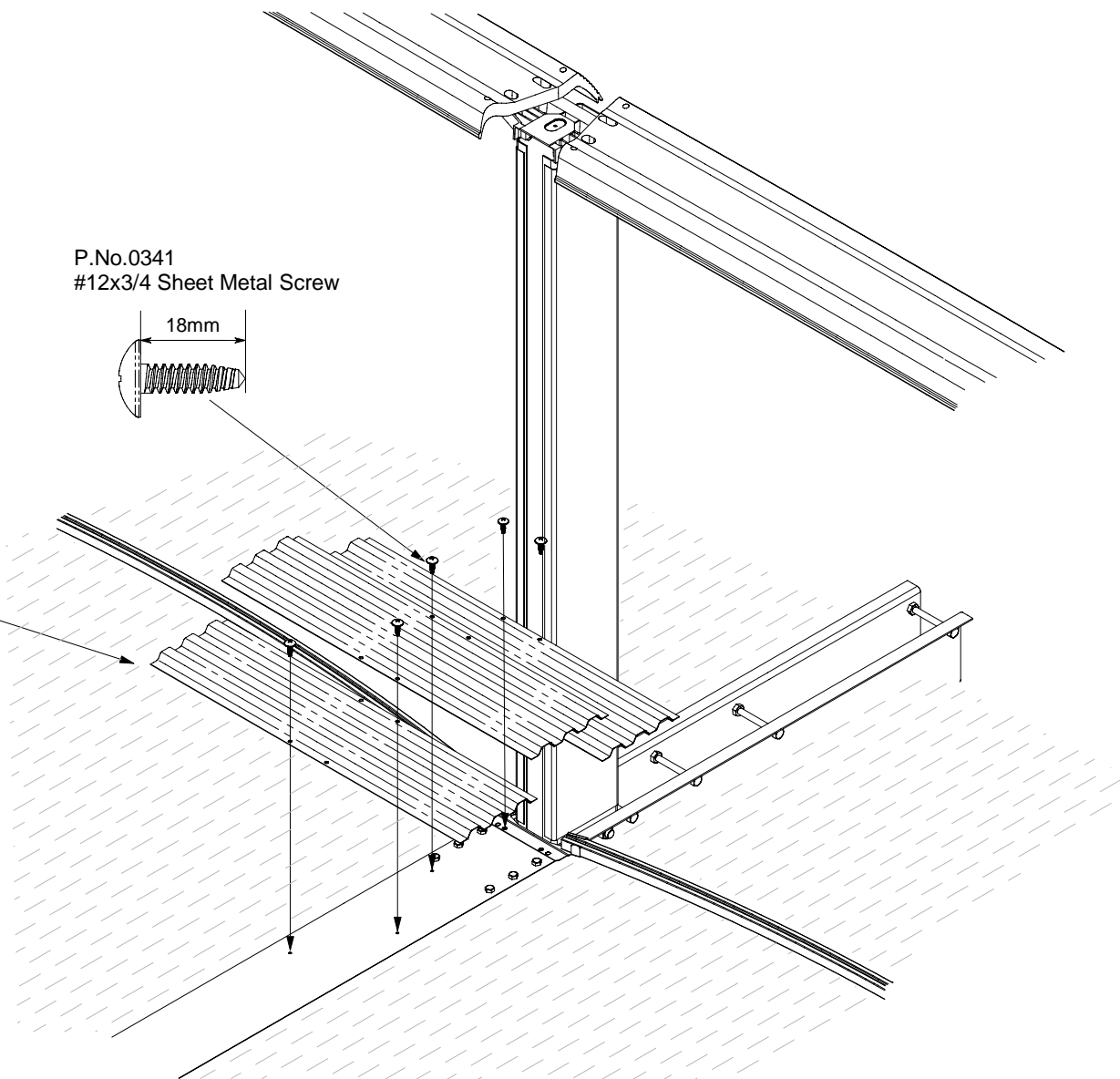
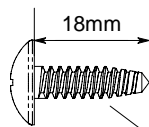

## 7) ASSEMBLING BOTTOM RAIL

STEP 1: Before proceeding, remove the steel wall from carton and stand on a 3'x3' board inside pool area as shown at down. Put the liner, (leaving it in the carton) inside pool area.

STEP 2: Bottom rails between the horizontal supports are set up by inserting each end of bottom rail into side lower joint, Insert the bottom rails around the entire perimeter using lower joints on the circular portion of the pool. Leave one section open that will be nearest to where you will locate your filter. Before proceeding to the next step, place a large amount of sifted earth in the middle of the circle. (see chart for the amount on the first page.) Sifted earth should not contain any pebbles.

Place a patio block under each lower joint around curved area. Make sure top of patio block is flush with ground surface and top of horizontal support.

## 8) INSTALLING WALL

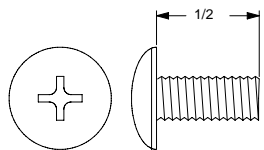

Use Wall Joint Bolt Package packed in a Wall Carton.

P.N.-0513  
1/4 x 1/2in Truss Head Screw



P.N.-0611  
1/4in Nut

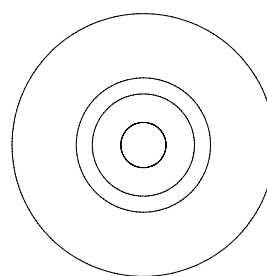
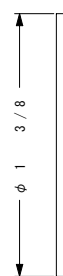

P.N.-0411  
1/4in Reinforcing Washer

Due to the weight of wall, some bending will occur in the top and bottom corrugation. because the wall is built to flex. Simply bend those sections back before inserting wall in top or bottom rail.

STEP 1: It is practical if two people work together; one inside and one outside of the pool.

STEP 2: Place coiled wall near bottom rail one section open.

Note: There is an up and down side on steel wall. Locate the skimmer cutouts which are near the outside end of the wall. These cutouts must be at the TOP even if you will not be using these cutouts.

STEP 3: Bring the wall close to the bottom rail. Make sure there is nothing in the bottom rail before inserting the wall. If there is earth or something is in the bottom rail, take out it accordingly. Begin to insert end of wall into bottom rail. One person unwinding wall (wall should be on a plywood base for ease of rotating) while the other person is feeding wall into slot of bottom rail around entire pool. As you unwind the wall and insert it into the assembled bottom rails, temporarily place top rail sections on top of the wall. This will help to prevent the wall from bending or falling over. Should the wall be either too short or too long, Adjust bottom rails, The circumference of bottom rails can be adjusted slightly by equally tapping outward or inward at the each lower joint until the wall ends meet.

Step 4: Bring the two open ends of the wall together as shown above. This is one of the most important steps in assembling the pool. Pay close attention to the following points.

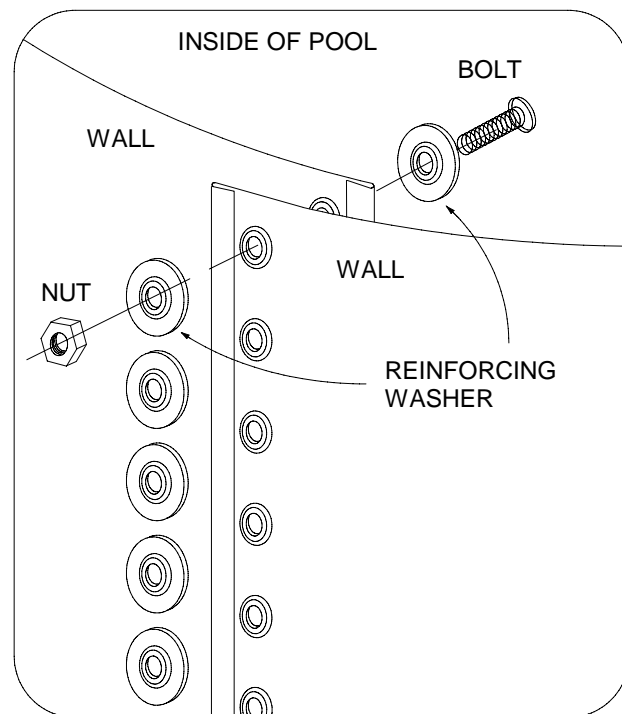

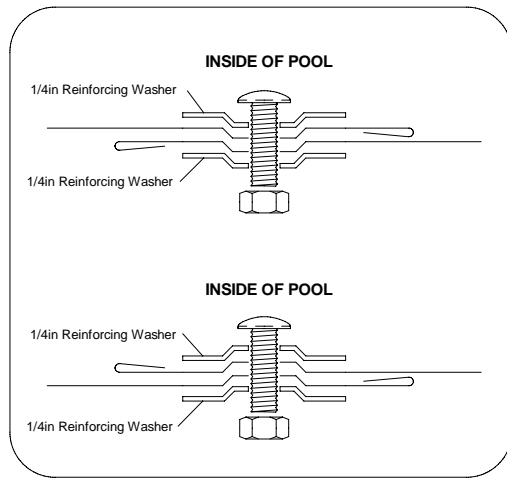

DO NOT FASTEN THE WALL WITHOUT USING THE REINFORCING WASHERS ! FAILURE TO USE REINFORCING WASHERS AS INSTRUCTED WILL CAUSE WALL TO SPLIT WHEN POOL IS FILLED. THIS CAN CAUSE SERIOUS PROPERTY DAMAGE AND/OR BODILY INJURY.

INSERT THE SCREWS FROM INSIDE OF WALL. NUT MUST BE FASTENED FROM OUTSIDE OF WALL.

- \* Reinforcing Washers must be on INSIDE and OUTSIDE of wall.
- \* Insert the screws from INSIDE of the wall.
- \* Insert and fasten screws from hole to hole down to the bottom of the wall. Do not fasten tightly before insert all screws.
- \* Fasten all screws tightly.
- \* Do not leave any open holes.
- \* Cover all the screw heads with strip of fabric tape.
- \* Check the level of the top of the wall, if more than 2" off level, Rework the ground to achieve levelness.

## 9) BUILD AN EARTH MOUND(cove)

Build a mound 6" high and extending 8 to 10" on the ground around the inside of the pool wall. Pack the earth gently but firmly.

IMPORTANT:

The earth mound must be built right. you must rebuild the earth mound each time you set up the pool. Water pressure can force the liner out under the bottom rail. If this is not done, this could cause damage to the liner and void warranty. The earth mound will prevent this from happening.

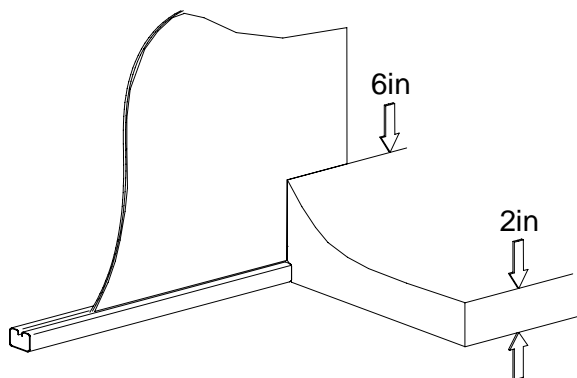

## 10) THROUGH THE WALL SKIMMER

Step 1: For unrusting, All edges of cut out have to be covered by vinyl tape or rusting paint. Begin the installation of the through the wall skimmer. Follow separate skimmer installations.

At one point during the installation of the skimmer, you have to install the liner. The skimmer installation will tell you when. Complete the installation of the liner as described next. Then finish the skimmer installation.

## 11) LINER INSTALLATION

CAUTION:

Remove your shoes. The liner should never be forcefully pulled or dragged, especially when it holds water, even only 1/2". When you enter the pool during installation, use a ladder other than a pool ladder. Make sure the legs rest on a strong flat board

- Step 1: Open the liner carton carefully by removing the tape. (Do not cut open carton.)
- Step 2: Unfold the liner inside the metal wall. Carefully spread it out on the ground. The seam around the bottom of the liner should be well up the earth mound. Do this evenly all around pool.
- Step 3: Remove top rail temporarily placed. Lift the side of the liner over the top of the wall. Form a collar approximately 3" down the outside of the wall and temporarily tape it, to the outside of the wall using masking tape at intervals of 3'.

Take the plastic edging and clip it over the liner and the top of the wall. The ends of each section of edging should touch each other. The edging forms a full circle all around. Cut off excess plastic edging

- Step 4: If the liner does not fit evenly around the pool. Remove the masking tape gently from the collar of the liner and wall. Smooth out all wrinkles on the bottom of the liner. There may be extra material around the side. Spread it evenly all around the side of the pool. There may be extra material in height.

*Please refer to "Assemble TopSeat, Vertical and Cover" of an attached sheet*

## 12) FILLING THE POOL

**The hard work is all behind. Now the fun begins.**

When pool is completely assembled and ready for water, run water into the pool. Wrinkles in pool liner should be smoothed out as water is added for easier maintenance.

IMPORTANT: STOP FILLING POOL AT 1 FOOT DEPTH

1) INSPECT BOTTOM RAILS-make sure they are not scalloped, see detail at right. If rails scallop, pull outward at the bottom of the verticals to allow wall and rails to assume natural shape. By using a string and small weight, check each vertical. To see that they stand straight. Be sure each vertical stands perfectly straight.

2) Measure all around the pool, from the TOP RAIL down to WATER LEVEL. This level SHOULD NOT VARY MORE THEN ONE INCH. An unlevelled condition will cause overstress of the pool wall and frame. Remove excess soil as required to establish a level frame and bottom rail condition.

See " ASSEMBLY OF BOTTOM RAILS "

3) Set as many hoses as you want to help speed up filling time. The pool holds a considerable amount of water (ie; 18' round pool holds 7650 gallons.).

4) To keep the water clean and protect your liner from being damaged it is best to cover hose end(s) with several layers of rags.

5) When desired water level is reached, turn on your filter. (Follow separate instructions provided with your filter.)

CAUTION:

Do not attempt to straighten liner after you begin to fill with water. Severe damage could be caused and You will void warranty.

### 13) HELPFUL INFORMATION

- Proper filtering and chemical treatments should not make it necessary to change the pool water. Your pool dealer will advise you of the proper procedure. To estimate the amount of chemicals needed here is the approximate water content of the pool based on full capacity:

Pool Size	Capacity gallons	Pool Size	Capacity gallons
16x12x48	4,661	16x12x52	5,050
20x12x48	6,079	20x12x52	6,585
24x12x48	7,493	24x12x52	8,117
25x15x48	9,675	25x15x52	10,481
30x15x48	11,910	30x15x52	12,902
33x18x48	15,541	33x18x52	16,836
41x21x48	22,721	41x21x52	24,614

- To help keep the pool clean and child proof, a pool cover should be on the pool whenever it is not in use. This also reduces loss of water and chemicals. To keep the pool in working condition check the following operation.
  - Leaks in skimmer and filter connections must be stopped. A constant drip of chlorinated water on metal will corrode the metal.
  - The pool should be left up and filled year round properly winterized and covered with a good cover. The water level must be lowered to about 6" below the lowest skimmer opening if your area is subjected to be below freezing temperature. All pool leaks must be repaired before winter.
  - Do not empty your pool in spring. Filtration and chlorination will remove all impurities. Leaves and other matter should be skimmed or vacuumed out of the pool.



### 14) SAFETY RULES

- Read your instructions and safety rules carefully. If you do not follow the safety rules someone could be injured or damage could occur.
- Plan carefully where you are going to put your pool. It must be close to a water source for filling. Also think about draining your pool.
- Never let anyone swim alone. Children must be carefully watched. For added safety, install a convex type mirror above pool to give full view of interior. Available at most mirror dealers.
- Do not let anyone rough-house in or around your pool. The pool area and decks can be slippery. Someone could be badly injured. You can prevent this type problem by enforcing the safety rules.
- Always keep the water clean and sanitary. Dirty water can be dangerous. Use your filter system. Follow instructions included with your filter. Also use water purifying chemicals as needed.
- DO NOT DIVE OR JUMP INTO YOUR POOL. THE POOL IS NOT DESIGNED FOR DIVING OR JUMPING !**
- Remove ladders when there is no adult to watch the pool. Remove anything else that can be used get into the pool. Use a cover if the pool is not in use for a long period of time.

**SAFETY DECALS CAN BE AFFIXED TO A CLEAN, DRY, SMOOTH SURFACE SUCH AS THE VINYL LINER, TOP SEAT THAT HAS SMOOTH FINISH. THEY MUST BE PLACED THAT THEY ARE EASILY SEEN.**

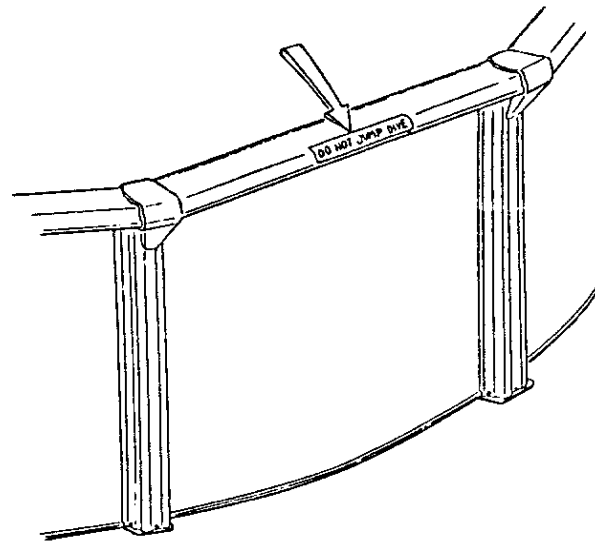

**Jumping and diving into a ASAHI CHEMICAL's Pool is *STRICTLY FORBIDDEN*. It is your responsibility as the owner of the pool to do the following:**

- Do not locate pool near objects that would entice diving i.e. garages, tree, porches, etc.
- Do not let anyone use your pool unless they are fully aware of the DO NOT DIVE OR JUMP notice.
- Do not promote horse play or other activities that would cause injuries.
- Do not allow people to sit or walk on the top seat of the pool.

**IT IS YOUR RESPONSIBILITY AS A POOL OWNER TO INSURE THE SAFETY OF WHOMEVER USES THE POOL NOT THE MANUFACTURER.**

**READ ALL INSTRUCTIONS CAREFULLY BEFORE ASSEMBLING YOUR POOL.**

Read through all instructions completely and familiarize yourself with all pool parts and accessories before pool assembly. Damage may be done if all instructions are not carefully followed, and in such cases, will void manufacturer's warranty. When assembling pool, read through what you must do for each step, then proceed.

**WARNING**

**THIS POOL IS DESIGNED FOR SWIMMING ONLY. IT IS NOT INTENDED FOR DIVING OR JUMPING. FOR A MAXIMUM OF SWIMMING FUN, BE SURE TO FOLLOW ALL SAFETY RULES WHEN USING ANY SWIMMING POOL.**

## BRACELESS OVAL PARTS LIST

BL08-A CARTON									
Parts No.	Description	16x12x52	20x12x52	24x12x52	25x15x52	30x15x52	33x18x52	41x21x52	
5726	Horizontal Support	2	4	6	4	6	6	8	
6254	Pressure plate L=680mm(26-3/4")	6	12	18	12	18	18	24	
0109.PACK	Braceless Oval Frame Bolt Package	1	2	3	2	3	3	4	
0105.PACK	Strap Bolt Package	1	2	3				2	
0106.PACK	Strap Bolt Package				2	3	3	3	
	BRACELESS OVAL POOLS INSTRUCTION	1	1	1	1	1	1	1	
Contents of each Bolt Package.									
0109.PACK Braceless Oval Frame Bolt Package									
5673	M14 x 30 Hex Head Bolt								24
5672	M14 Nut								24
5674	M10 x 100 Hex Head Bolt								8
5675	M10 Nut								24
0341	#12 x 3/4 Sheet Metal Screw								10
0105.PACK Strap Bolt Package									
0623	M8 Nut								22
0923	M8 x 20 Hex Head Bolt								22
0106.PACK Strap Bolt Package									
0623	M8 Nut								27
0923	M8 x 20 Hex Head Bolt								27

BL08-B CARTON for 52"								
5712	Side Vertical for BLE 52"	2	4	6	4	6	6	8
5617	Side Vertical Skin for 52" or 54"	2	4	6	4	6	6	8
7528	End strap L=1400mm(55-1/8")	2	4	6	4	6	6	6
7254	Middle strap L=835mm(32-7/8")	1	2	3				
7244	Middle strap L=929mm(36-5/8")				4	6		
7264	Middle strap L=1405mm(55-3/8")						6	
7285	Middle strap L=1287mm(50-5/8")							12
BL08-B CARTON for 54"								
5713	Side Vertical for BLE 54"	2	4	6	4	6	6	8
5617	Side Vertical Skin for 52" or 54"	2	4	6	4	6	6	8
7528	End strap L=1400mm(55-1/8")	2	4	6	4	6	6	6
7254	Middle strap L=835mm(32-7/8")	1	2	3				
7244	Middle strap L=929mm(36-5/8")				4	6		
7264	Middle strap L=1405mm(55-3/8")						6	
7285	Middle strap L=1287mm(50-5/8")							12

Nov. 2007