

| Parts List | | |
|------------|-----|----------------|
| ITEM | QTY | PART NUMBER |
| 1 | 32 | COP-KCVRET-W-1 |
| 2 | 2 | IPC-AB90 |
| 3 | 28' | OPC-CONREC-PFT |
| 4 | 30' | SSC-1099 |
| 5 | 1 | SSC-2490 |
| 6 | 1 | SSC-2491 |
| 7 | 1 | SSC-2507 |
| 8 | 1 | SSC-2508 |
| 9 | 1 | SSC-2509 |
| 10 | 1 | SSC-2510 |
| 11 | 1 | SSC-2511 |
| 12 | 1 | SSC-2512 |
| 13 | 2 | SSC-2513 |
| 14 | 2 | SSC-2514 |
| 15 | 2 | SSC-2515 |
| 16 | 2 | SSC-2516 |
| 17 | 2 | SSC-2517 |

NOTE: PVC 6 " RADIUS INSERTS WILL BE PROVIDED WITH ALL STEP/BENCH KITS THAT HAVE 90 DEGREE CORNER.

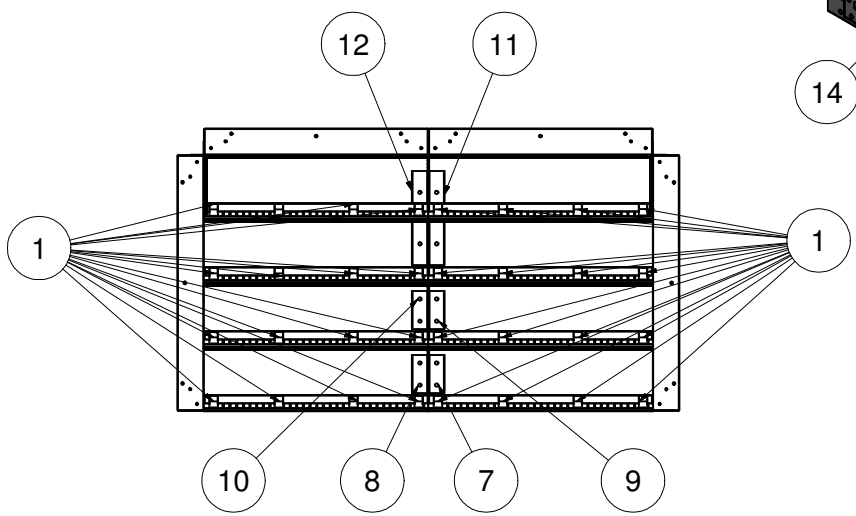

OT STEP STR-90D 4 TRD 7'

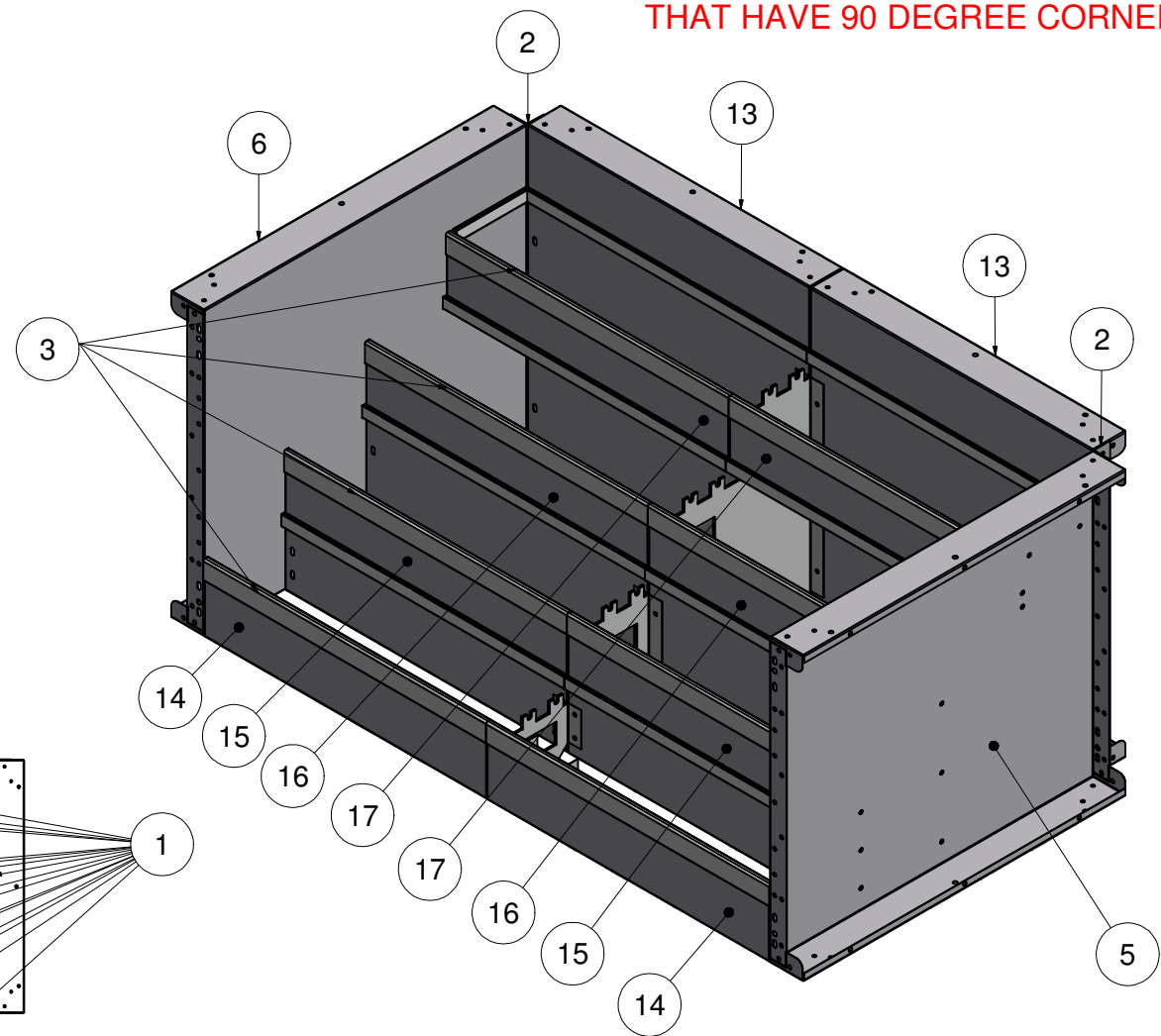

TOLERANCES EXCEPT AS NOTED:
 0/0 0.0 0.00 0.000 0°
 ±1/8 ±0.25 ±0.0625 ±0.03125 ±1/2°

DATE : 1/12/2017
SHEET : 2 OF 2

PART # : SOK-ST084ST904T
SECTION : 2 - 4