



Hayward and Goldline Controls-brand electronic chlorine generation systems all generate their own chlorine from a low concentration of salt dissolved into the pool water to create 100% of the pool's sanitizing needs.

Will the pool water taste salty?

No. The concentration of salt in the pool water is approximately 1/10 of the level in the ocean and is below the level of taste for most people. This level of salt is equivalent to 1 teaspoon of salt in a gallon of water. Encourage anybody who is concerned to do a "taste test".

Types of salt

Electronic chlorine generators use ordinary food grade, solar salt or water softener salt. Regardless of which type of salt you chose ensure that it is at least 99% pure salt (NaCl). Never use rock salt (ice melt) or salts that have more than 1% of "anti-caking agents", "yellow prussiate of soda", or "sodium ferrocyanide" added as these compounds may cause staining of the pool. Salt is available from most distributors in 40–80 pound bags.

Amount of salt to add to the pool

Hayward and Goldline Controls-brand electronic chlorine generation systems require salt levels between 2700 and 3400 ppm. This amount of salt is below the level of taste for most people and is the equivalent of 1 teaspoon of salt per gallon. **Since all chlorine added to a pool eventually reverts to salt, it is very important to measure the salt level in existing pools before adding any salt.**

How to add salt

After determining the amount of salt to add from the table above, hold 1 or 2 bags in reserve. Dump the remaining bags directly into the pool and brush the salt around to speed up the dissolving process. Do not allow the salt to sit in a pile at the bottom of the pool. Salt water is heavier than fresh water so the salt water will tend to accumulate at the deepest part of the pool. Run the filter system with the suction coming from the main drain for 24 hours to evenly distribute the salt throughout the pool. Note: For new plaster pools, consult with the applicator for the recommended cure time before adding salt.

Salt Display

The salt display responds slowly to rapid changes in salt level. It takes up to 24 hours of circulation for the salt to be evenly distributed in the pool. Be patient and do not over-react by adding too much salt. If the salt level is still low after 24-48 hours, add the reserve bags (see "How to add salt" above) to the pool.

Pounds of Salt Required for 3200 ppm

Current Salt Level (ppm)	Pool Size – Gallons																
	8,000	10,000	12,000	14,000	16,000	18,000	20,000	22,000	24,000	26,000	28,000	30,000	32,000	34,000	36,000	38,000	40,000
0	213	267	320	373	427	480	533	587	640	693	747	800	853	907	960	1013	1067
200	200	250	300	350	400	450	500	550	600	650	700	750	800	850	900	950	1000
400	187	233	280	327	373	420	467	513	560	607	653	700	747	793	840	887	933
600	173	217	260	303	347	390	433	477	520	563	607	650	693	737	780	823	867
800	160	200	240	280	320	360	400	440	480	520	560	600	640	680	720	760	800
1000	147	183	220	257	293	330	367	403	440	477	513	550	587	623	660	697	733
1200	133	167	200	233	267	300	333	367	400	433	467	500	533	567	600	633	667
1400	120	150	180	210	240	270	300	330	360	390	420	450	480	510	540	570	600
1600	107	133	160	187	213	240	267	293	320	347	373	400	427	453	480	507	533
1800	93	117	140	163	187	210	233	257	280	303	327	350	373	397	420	443	467
2000	80	100	120	140	160	180	200	220	240	260	280	300	320	340	360	380	400
2200	67	83	100	117	133	150	167	183	200	217	233	250	267	283	300	317	333
2400	53	67	80	93	107	120	133	147	160	173	187	200	213	227	240	253	267
2600	40	50	60	70	80	90	100	110	120	130	140	150	160	170	180	190	200
2800	27	33	40	47	53	60	67	73	80	87	93	100	107	113	120	127	133
3000	13	17	20	23	27	30	33	37	40	43	47	50	53	57	60	63	67
3200	ideal	ideal	ideal	ideal	ideal	ideal	ideal	ideal	ideal	ideal	ideal	ideal	ideal	ideal	ideal	ideal	ideal
3400	ok	ok	ok	ok	ok	ok	ok	ok	ok	ok	ok	ok	ok	ok	ok	ok	ok

Goldline – Chlorination



Pool Chemistry

FOR ELECTRONIC CHLORINE GENERATORS



It is important to maintain salt and stabilizer levels in order to prevent scaling and to ensure maximum enjoyment of the pool. Test the water periodically and use standard pool industry procedures to adjust levels.

Salt 2700 to 3400 ppm

Check monthly (using the digital salt display). The higher end of the salt level range lets the electronic chlorine generator produce more chlorine and also helps extend the life of the cell. The electronic chlorine generator will indicate when the salt drops below 2700 ppm and the electronic chlorine generator will stop operating if the salt drops below 2500ppm. On most pools, the salt level tends to slowly drift downward as fresh water is added to the pool (rain or makeup water for splash-out, back-washing etc.). A good procedure is to add enough salt to be near the top of the range. Usually add stabilizer (see below) at the same time.

Stabilizer 60 to 80 ppm

Check monthly. Stabilizer is also known as conditioner, cyanuric acid, or isocyanuric acid. Refer to local codes regarding its use. Stabilizer helps maintain the chlorine residual in the pool by protecting it from the UV rays from the sun. Without stabilizer, the electronic chlorine generator would have to produce much more chlorine in order to keep the desired residual level in the pool. Add enough stabilizer to be near the top end of the range at the same time you add salt.

Chlorine

Ideally, all of the chlorine in the pool should be “free chlorine” and there should be zero “combined chlorine.” “Free chlorine” means that it is not attached to any contaminants in the pool and is ready to attack any algae or bacteria that it comes in contact with. Note that test kits using the OTO method (yellow color) only test total chlorine and can not differentiate between “free” and “combined”. DPD test kits (red color) do allow for the testing of both total chlorine and “free chlorine”.

pH determines Chlorine effectiveness

The recommended pH range is 7.2 to 7.8. If the pool’s pH rises above the top end of the range, the sanitizing effectiveness of the chlorine can be greatly reduced. For example: The chlorine in a pool with the pH at 7.2 is approximately ten times more effective than the same amount of chlorine in a pool with the pH at 8.2.

Why is water chemistry important?

Continuous filtration, cleaning and sanitization are not enough — balancing pH (potential hydrogen) is vital. Chlorination should keep germs and algae at bay but when pH is unbalanced, it can’t do its job. Let the pH drop too low and the water becomes acidic and attacks anything it touches. When pH drifts up, the water becomes alkaline and creates an environment where mineral deposits (scale) can form. Furthermore, when pH is high, chlorine becomes less effective at its primary task — killing bacteria and algae.

ORP (oxidation reduction potential) measures the oxidizing capacity in water. It is a proven measurement and maintenance technology mandated for commercial pool sanitization. Unlike most home-test processes, ORP is not fooled by the effects of pH, TDS (total dissolved solids) and other factors. Most home-test kits and strips only report free chlorine and other less effective forms of chlorine. Only ORP can deliver further detailed analysis of the more important free chlorine. It differentiates free chlorine’s components HOCl (hypochlorous acid) and OCl- (hypochlorite ion). OCl- is a slow-acting sanitizer, and HOCl is up to 300 times more effective. ORP targets HOCl, a more fine-tuned measurement of the effectiveness of chlorine and water quality.

Studies have reported on the relationship between ORP and chlorine’s activity with germs and bacteria. They’ve concluded that ORP significantly predicts water bacterial quality better than other methods. As a result, in most states, the highly regulated commercial pool industry requires ORP testing.

What is balanced water?

Water balance is composed of several key factors — pH, total alkalinity, calcium hardness and TDS. All of these factors are important, but none more so than pH. pH is a measurement of the concentration of hydrogen ions in water. It is measured using a logarithmic scale from 0 to 14, with pH 7 being neutral.

For pool water to be in balance, all factors must be in their proper range. That range may vary slightly depending on the finish of the pool and the average temperature of the pool water. The one value that never changes is pH. It must be maintained between 7.2 and 7.8 for a pool to be considered “balanced.”

WATER QUALITY PARAMETER	IDEAL LEVELS
Salt	2700 to 3400 ppm
Free Chlorine	1.0 to 3.0 ppm
pH	7.2 to 7.8
Cyanuric Acid (Stabilizer)	60 to 80 ppm (80 ppm best)
Total Alkalinity	80 to 120 ppm
Calcium Hardness	200 to 400 ppm
Metals	0 ppm
Saturation Index	-2 to 2 (0 basil)

Install the cell and flow switch downstream of all existing equipment, but prior to the pool/spa return valve. The flow switch can be located immediately downstream from the cell (as shown) or can be installed with 12" of straight pipe directly before the mounting tee (option 1 below). For stand alone any Aqua Rite installations on pool/spa systems, refer to options 2 or 3 in order to avoid possible over chlorination of the spa.

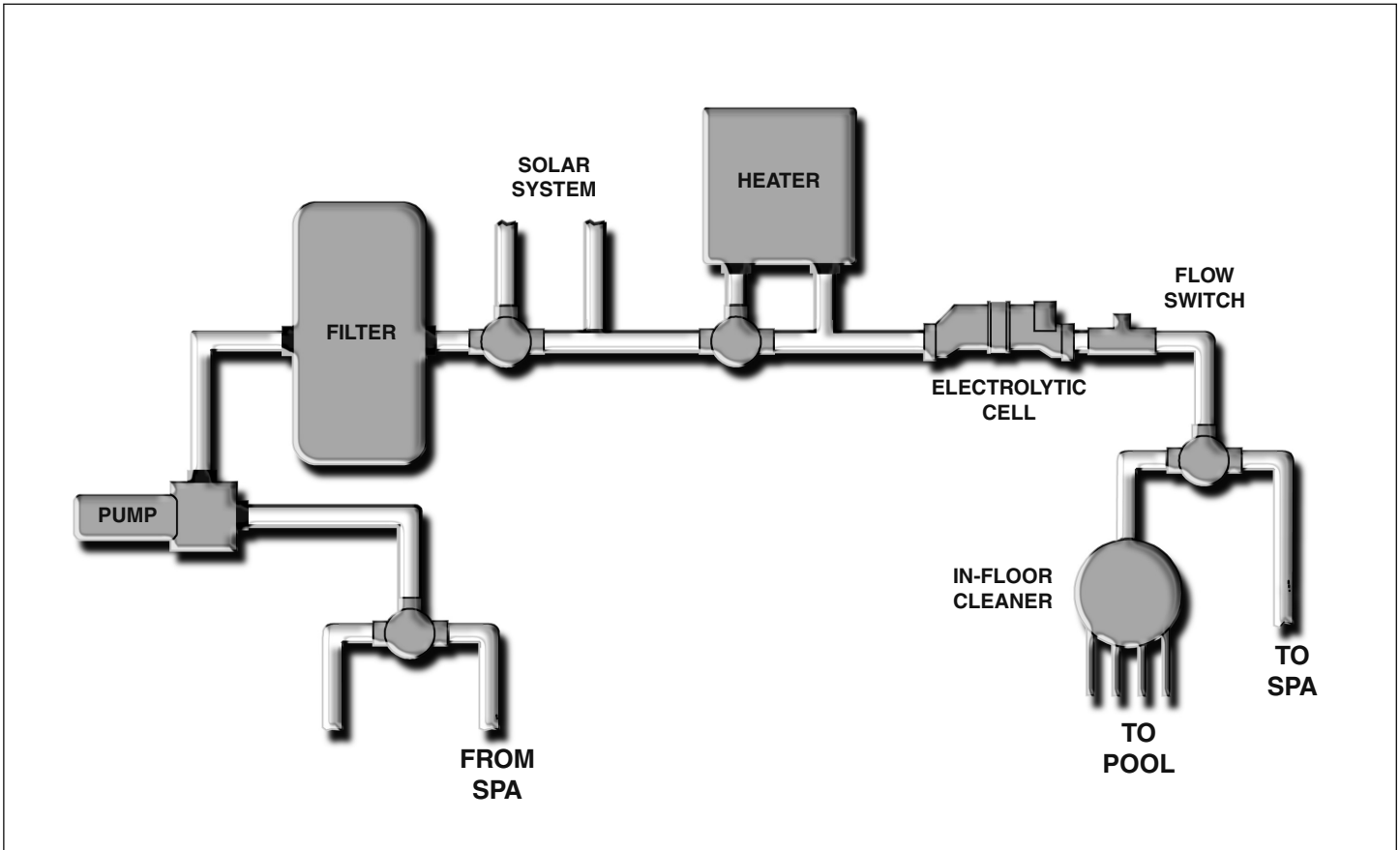

Chlorinator Cell

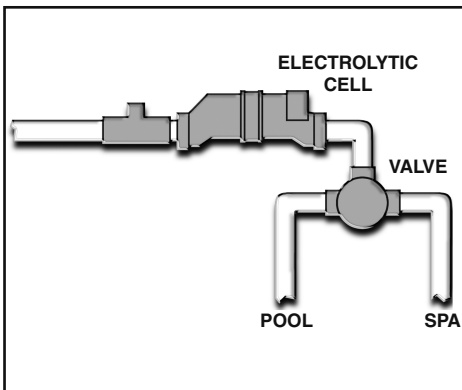

Optional Configuration #1

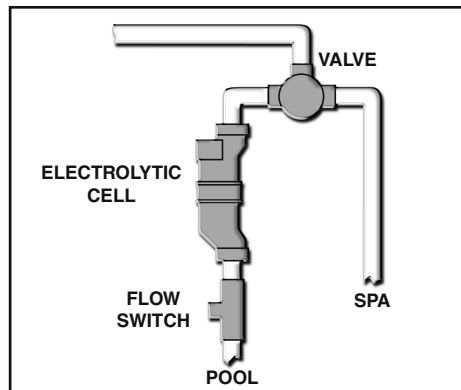

Optional Configuration #2

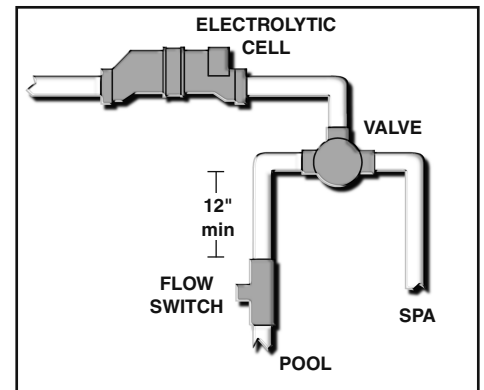

Optional Configuration #3